

SKF

SNL 30 and SNL 31 plummer block housings solve the housing problems

(Replace SD housing range)



Contents

Made by SKF® stands for excellence. It symbolises our consistent endeavour to achieve total quality in everything we do. For those who use our products, “Made by SKF” implies three main benefits.

Reliability – thanks to modern, efficient products, based on our worldwide application know-how, optimised materials, forward-looking designs and the most advanced production techniques.

Cost effectiveness – resulting from the favourable ratio between our product quality plus service facilities, and the purchase price of the product.

Market lead – which you can achieve by taking advantage of our products and services. Increased operating time and reduced down-time, as well as improved output and product quality are the key to a successful partnership.



1 Product information..... 3

Fewer bearing replacements and less maintenance... 3
Plummer block housings have much to offer..... 3
SNL 30 and SNL 31 plummer block housings have more to offer..... 3
One basic design – many variants..... 4
Costs and risks – at a low level 6
High performance for all sectors 8

2 Recommendations..... 10

Bearing arrangement design 10
Bearings on adapter sleeves on smooth shafts 10
Bearings on cylindrical seatings on stepped shafts 11
Standard seals 12
Special seals..... 15
End covers 17
Locating rings 17
Application advice for trouble-free operation..... 18
Lubrication 20
Mounting 22
Mounting SNL 30 and SNL 31 housings with labyrinth seals..... 24
Mounting SNL 30 and SNL 31 housings with taconite seals 26
Mounting SNL 30 and SNL 31 housings with oil seals 28

3 Product data 30

Designations and housing data 30
Designations 30
Load carrying ability 31
Product tables..... 34
Large SNL plummer block housings for bearings on adapter sleeve 34
Large SNL plummer block housings for bearings with cylindrical bore 42

Other products for trouble-free operation..... 48

The SKF Group – a worldwide corporation..... 54

Fewer bearing replacements and less maintenance

1

Plummer block housings have much to offer

The main benefit of split plummer block housings is their easy installation; pre-assembled shafts can be mounted in them. When the housing bases are attached to the base plate it is then only necessary to place the housing caps in position and to tighten the attachment bolts to complete the installation.

Split plummer block housings available on the market are mainly intended for self-aligning ball bearings, spherical roller bearings and CARB® bearings of ISO Dimension Series 02, 03, 22, 23, 30, 31, 32, 39, 40 and 41. They can often be fitted with various different seals. Many designs and variants of split plummer block housings are available making the use of tailored housings unnecessary and thus enabling cost effective bearing arrangements to be made.

For many years SKF has been one of the leading suppliers of various designs of split plummer block housings, including the SD plummer block housings – synonymous with operational reliability and quality.

SNL 30 and SNL 31 plummer block housings have more to offer

SKF plummer block housings of the SD design are currently being redesigned to take advantage of the progress embodied in the smaller SNL housings. The new plummer block housings of series SNL 30 and SNL 31 will gradually replace the SD housings and are also referred to as “Large SNL plummer block housings”.

The new SNL plummer block housings enable the full service life potential of the incorporated bearings to be exploited with less need of maintenance. This supports user efforts to further reduce maintenance costs. Among other enhancements the SNL housings have a new external design for easier alignment and handling when mounting.

Another benefit is the choice of oil or grease lubrication for the bearings housed in SNL plummer blocks. A range of newly developed seals for oil lubrication and rough environments make for trouble-free operation.



One basic design – many variants

Large SNL plummer block housings are primarily intended for spherical roller bearings and CARB bearings. The housings are designed on a “building block” principle. This enables a more generous choice of bearing, shaft mounting, seals and type of lubrication.

A building block system

The basis of the original SNL plummer block housing system consists of a number of housings of the same design but in different sizes. By combining the housings with the different standard seals a wide variety of housing variants, all belonging to the standard range, can be supplied to cover the majority of demands for plummer blocks.

When complete, the new range of series SNL 30 and SNL 31 will be available for shafts having diameters of 150 to 500 mm, inclusive. However, initially the range extends to shaft sizes up to 300 mm; the larger sizes will gradually become available as design work is completed. The availability of housings for which only shaft size and designations are given in the product tables should be checked before ordering.

The standard range will also cover housings with drilled and tapped holes for lubrication nipples. There are variants to be drilled upon request for condition monitoring.

Series SNL 30 and SNL 31 plummer block housings are made of grey cast iron and demonstrate the same high strength as the earlier SD housings. Should, however, this strength be inadequate, dimensionally equivalent SNLD plummer block housings of spheroidal graphite cast iron are available.

The large SNL and SNLD plummer block housings are fully interchangeable with the earlier SD and SDD housings. Their dimensions conform to ISO 113:1999.

Several sealing options

An important advantage of the SNL plummer block housings is that they can be fitted with different seals. The standard seals supplied by SKF for the large SNL 30 and SNL 31 series housings comprise labyrinth seals and heavy-duty “taconite” seals as well as end covers. There is also an oil seal available but this sealing arrangement is supplied together with the housing as the housing has to be modified to take it.



Costs and risks – at a low level

The new SNL 30 and SNL 31 plummer block housings represent a further development of the SD housings. These large SNL housings have several special features as well as sealing alternatives.

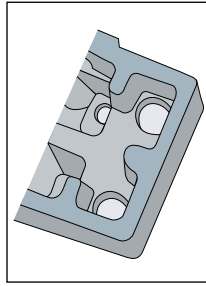

Reinforced square base

The housing base is reinforced with walls around the holes for the attachment bolts in order to provide improved seating on the base plate. The attachment bolts can be preloaded to give better location and can no longer deform the housing base or housing bore.

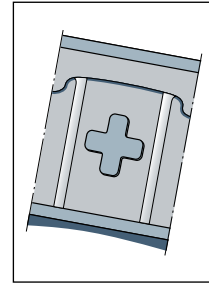

Enlarged contact area

The centre cross reinforcement of the housing base enlarges the contact area between base and base plate and allows for an improved heat flow from the bearing outer ring to the base plate.

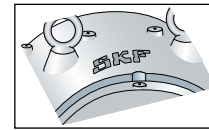

Drilled and tapped holes

Housings have drilled and tapped holes as standard in the cap. The holes are protected by metallic plugs. Two nipples are supplied, together with nipple protector and adapter, with the housing (packed inside). If the application is such that relubrication is required it is only necessary to screw the nipples into the holes and lubricant can be supplied to one side of the bearing or in the W33 groove. There are also indications on the housing where holes can be drilled for lubrication of the seals.

- | | |
|--|---|
| ● Reinforced square base | Increased stiffness |
| ● Enlarged contact area | Reinforced housing base and improved heat flow |
| ● Drilled and tapped holes with nipples | Relubrication facility as standard |
| ● Caps and bases individually marked | Avoids mixing of caps and bases, permits traceability |
| ● Indications for holes to take other components | Simple and easy adaptation of standard housing to individual application, easy attachment of condition monitoring equipment |
| ● Simple and reliable | Simpler and more reliable mounting and maintenance |
| ● Additional seals | Extended range of use, longer bearing service lives |

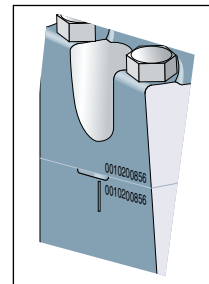

Caps and bases individually marked

The housing base and cap are matched during manufacture and are not interchangeable with the caps and bases of other housings. To prevent mixing caps and bases when mounting several housings, the same consecutive number is marked on the cap and base of each individual housing.

Design characteristics

Page 10

Page 30

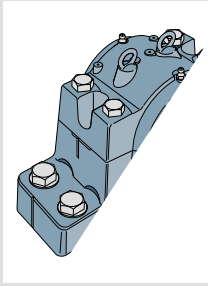

Indications for holes to take other components

SNL housings can be fitted with sensors serving permanently installed condition monitoring equipment based on vibration measurements. The positions where holes can be drilled to take these sensors are indicated on the housing.

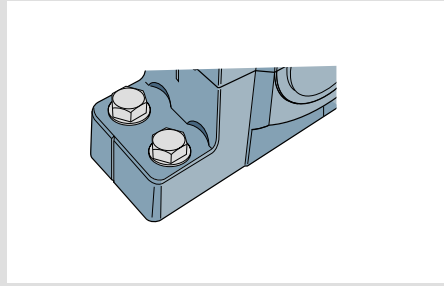

Simpler and safer

In order to simplify mounting and make alignment more accurate, cast indications, which are vertical to the centre of the bore of the housing, are provided on the side faces of the housing base. Cast indications on the end faces of the base show the centre of the bearing.

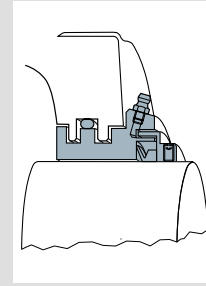

Additional seals

Two new seal designs have been developed specifically for SNL housings. One is intended for difficult conditions that call for a robust seal which can be relubricated and the other is for high speeds and oil lubrication.

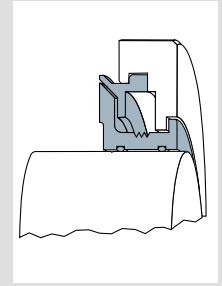

High performance for all sectors

High load carrying capacity and reliability, easy maintenance, the variety of applications and robust designs have made SKF housings a must. The most important sectors of industry and their demands are listed below.

One important reason for the popularity of SKF housings is the increased awareness of the impact of enhanced quality on the cost of a machine and its total life.

Industry

- Materials handling
- Handling systems
- Mining and construction
- Fluid machinery
- Metallurgical
- Pulp and paper

Demands

- Long service life
- Robust design
- Long relubrication intervals
- Ready for relubrication
- Condition monitoring facilities
- Avoid risk of mixed caps
- Fast and easy mounting and dismounting

Solution





1



Bearing arrangement design

Large SNL plummer block housings of series SNL 30 and SNL 31 can be used with spherical roller bearings or CARB bearings fitted on smooth (plain) or stepped shafts; the bearings can be mounted on adapter sleeves or directly on cylindrical shaft seatings.

1. Bearings on adapter sleeves on smooth shafts

Advantages

- Shafts with diameter tolerance h9 can be used without machining
- Maximum shaft strength as there is no weakening by shoulders or reliefs
- Bearings can be mounted at any position on the shaft
- Mounting force, i.e. the force required to drive up the bearing on to the sleeve, is some 40 % smaller than with other bearing arrangements on sleeves because friction occurs only in one contact

- Bearing radial clearance can be adjusted within certain limits during mounting to meet application demands

Applications

- Bearing arrangements for relatively long shafts where more than two bearings are required for support
- Bearing arrangements where machine components are mounted using wedging or tensioning components which do not require the shaft to be machined
- Bearing arrangements where the final position of the bearing cannot be accurately determined

Bearings on adapter sleeves on smooth shafts

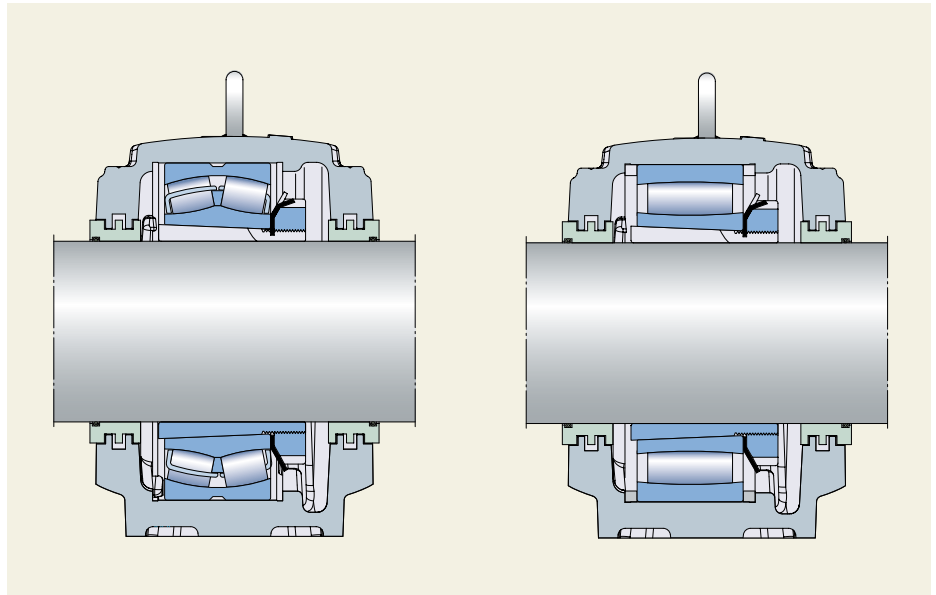

SNL 30

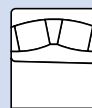

230 CCK

SNL 31

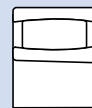

C 30 K

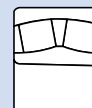

231 CCK

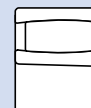

C 31 K

2. Bearings on cylindrical seatings on stepped shafts

Advantages

- The axial load carrying capacity of the bearings (in both directions) is not limited by a sleeve
- The residual bearing internal clearance is determined by the tolerance of the shaft seating so there is no danger of radially preloading the bearing during mounting
- The bearing position on the shaft is accurately determined by the shaft shoulder
- The bearing can be supported by other components via spacer sleeves
- The shaft diameter at the bearing position is maximised

Applications

- Bearing arrangements where large numbers of bearings have to be mounted
- Bearing arrangements where heavy shock loads can occur

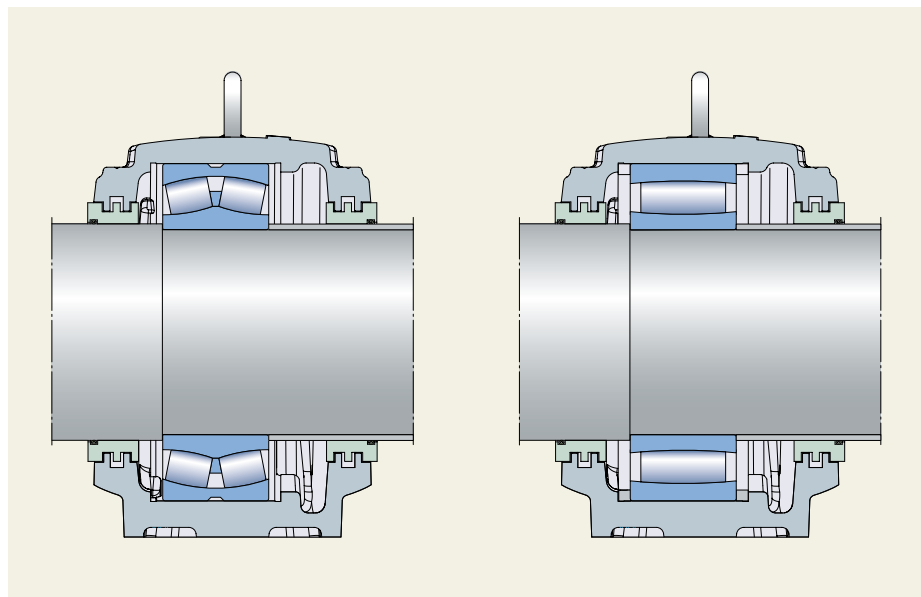

Bearings on cylindrical seatings on stepped shafts

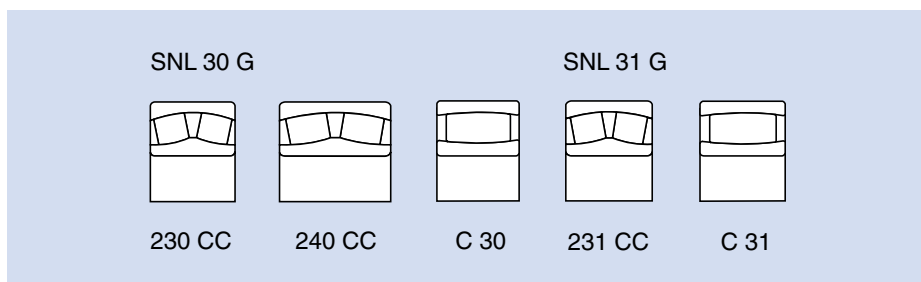

Standard seals

The standard seals available from SKF for large SNL housings (series SNL 30 and SNL 31) are one-piece labyrinth seals and the heavy-duty “taconite” seals. The seals are easy to install and are supplied separately.

The standard seals as well as the seals for use with oil lubrication are

presented in **Table 1**, which gives a comprehensive overview of the seal types, their design features and their suitability for various operating conditions. Detailed information on the various standard and special seals including properties and availability will be found on **pages 13 to 15**.

Seal selection

Table 1

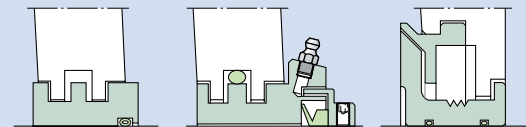

TS ..

TNF ..

TSD .. U¹⁾

Properties	TS ..	TNF ..	TSD .. U ¹⁾
Temperature, °C	-50 to +200	-40 to +100	-50 to +200
Peripheral speed, m/s	++	≤ 12	++
Misalignment, degrees	≤ 0,3	≤ 0,3	≤ 0,3
Grease relubrication	+	+	-
Oil lubrication	-	-	++
Low friction	++	+	++
Axial shaft displacement	+	+	-
Vertical arrangement	--	-	--
Sealing ability against			
Dust	+	++	+
Fine particulate contaminants	+	++	+
Coarse particulate contaminants	+	++	+
Abrasive contaminants	++	++	++
Liquids when sprayed	--	++	-
Direct sunlight	++	++	++
Symbols:	++ very suitable + suitable - limited suitability -- unsuitable		

¹⁾ The oil seals are supplied together with housings prepared for oil lubrication. Oil seals can be ordered separately as spares only

Labyrinth seals

The labyrinth rings (→ fig 1) are made of cast iron and have three radially arranged labyrinth steps which form a narrow sealing gap with the housing grooves.

Hollow O-ring cords of silicone rubber (supplied with the seals) ensure that the labyrinth rings, which are mounted with a loose fit, rotate with the shaft. Angular misalignments of the shaft up to approximately 0,3° are permissible. The operating temperature range for the labyrinth seals is -50 to +200 °C.

When labyrinth seals are used, axial movement of the shaft relative to the housing is not limited.

The labyrinth seals are supplied singly. For bearing arrangements for through shafts it is therefore necessary to order two rings. The labyrinth seal is identified by the prefix TS followed by the size identification, e.g. TS 34.

Taconite heavy-duty seals

Taconite is a very fine-grained mineral which is extremely difficult to seal against. For bearing arrangements which must operate under very arduous conditions such as those encountered in mining, labyrinth seals which can be relubricated are recommended, as grease enhances the sealing effect and extends the serviceability of the seals. SKF has developed a heavy-duty seal (which can seal against taconite, hence the name) which can be supplied for use with SNL housings.

The taconite seal design (→ fig 2) is based on a labyrinth seal with the labyrinth stages arranged axially and fits the standard housings. A V-ring seal mounted on the shaft seals against the non-rotating part of the seal, which is inserted in the seal groove and prevents contaminants from penetrating to the bearing when the seal is relubricated. This grease is supplied via a

grease nipple on the non-rotating part of the seal. Angular misalignments of the shaft of up to approximately 0,3° are possible.

The permissible operating temperature range for the seal is between -40 and +100 °C. Please contact SKF for applications above 100 °C. The rubber O-ring and V-ring limit the operating temperature to 100 °C. However, SKF can supply high temperature O-rings and V-rings made of fluoro rubber for operation at higher temperatures.

The axial movement of the shaft relative to the housing is limited for this type of taconite seal to approximately ±2 mm for sizes from 150 up to 200 mm and ±4 mm for larger shaft diameters.

These seals are supplied singly so that for housings used on through shafts, it is necessary to order two seals. The seal is identified by the prefix TNF followed by the size identification, e.g. TNF 34.

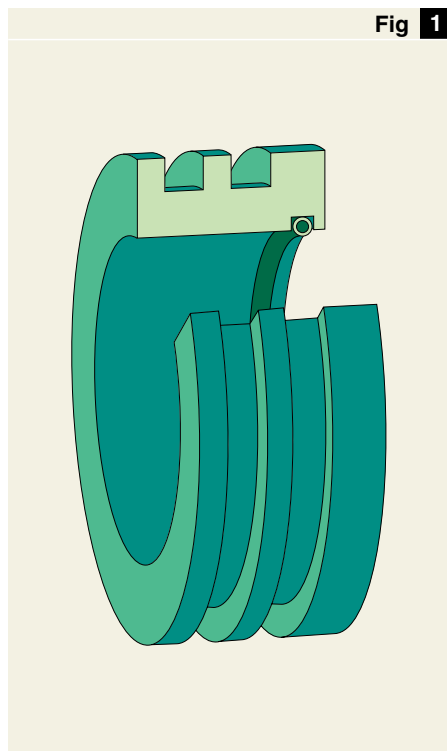
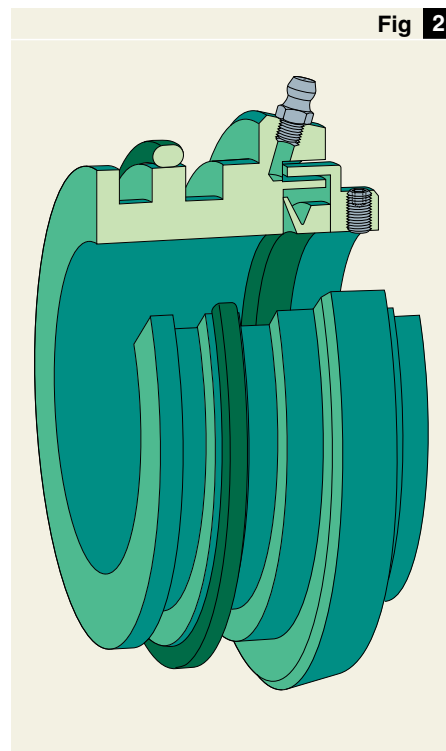
Labyrinth seal**Taconite heavy-duty seal**

Seals for oil lubrication

Special seals (oil seals) are required to prevent oil from escaping from the housing when oil lubrication is applied. For SNL housings, SKF has developed the non-rubbing seal of the U design (→ fig 3). These U seals require modified housings and comprise two parts: one which is stationary and fitted in the modified seal groove and the other which is mounted on the shaft and rotates. The hollow O-ring cords of silicone rubber inserted between the labyrinth ring and the shaft ensure that the ring, which is mounted with a loose fit, rotates with the shaft, and oil cannot escape along the shaft. These oil seals do not limit axial movement of the shaft relative the housing.

The modified SNL housing is supplied together with the seals as a unit. The housings with seals are identified by the suffix TURT (TURA for CARB bearings) e.g. SNL 3134 TURT. The seal itself is designated TSD .. U.

Oil seal

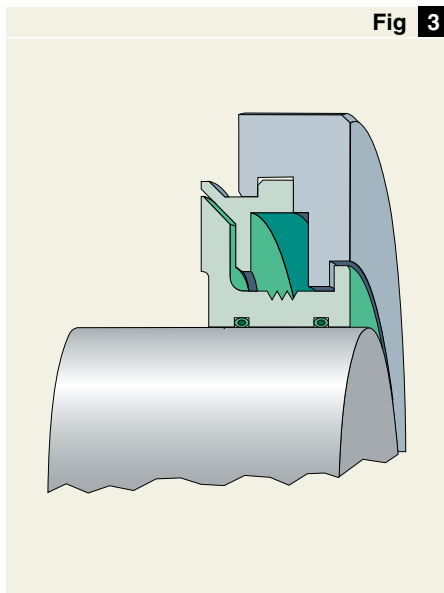

Fig 3

Table 2

Housing Size	Dimensions						
	A ₃	A ₄	A ₅	A ₆	D _b	D _c	D _d
–	mm						
SNL 3036	158	11	5,5	22	181,2	196,4	205,2
SNL 3038	168	11	5,5	22	191,4	206,4	215,4
SNL 3040	186	11	5,5	22	201,4	216,4	225,4
SNL 3044	206	11	5,5	22	221,4	236,4	245,4
SNL 3048	214	11	5,5	22	241,4	256,4	265,4
SNL 3052	231	11	5,5	22	261,6	276,6	285,6
SNL 3056	249	11	5,5	22	281,6	296,6	305,6
SNL 3060	249	11	5,5	22	301,6	316,6	325,6
SNL 3064	279	11	5,5	22	321,8	336,8	345,8
SNL 3068	299	11	5,5	22	341,8	356,8	365,8
SNL 3072	297	11	5,5	22	361,8	376,8	385,8
SNL 3076							
SNL 3080							
SNL 3084							
SNL 3088							
SNL 3092							
SNL 3096							
SNL 30/500							
SNL 3134	159	11	5,5	22	171,2	186,4	195,2
SNL 3136	169	11	5,5	22	181,2	196,4	205,2
SNL 3138	187	11	5,5	22	191,4	206,4	215,4
SNL 3140	207	11	5,5	22	201,4	216,4	225,4
SNL 3144	215	11	5,5	22	221,4	236,4	245,4
SNL 3148	231	11	5,5	22	241,4	256,4	265,4
SNL 3152	249	11	5,5	22	261,6	276,6	285,6
SNL 3156	249	11	5,5	22	281,6	296,6	305,6
SNL 3160	280	11	5,5	22	301,6	316,8	325,6
SNL 3164	300	11	5,5	22	321,8	336,8	345,8
SNL 3168							
SNL 3172							
SNL 3176							
SNL 3180							
SNL 3184							
SNL 3188							
SNL 3192							
SNL 3196							

For SNL 3076 to SNL 30/500 and SNL 3168 to SNL 3196, inclusive, please consult SKF

Table 3

Special seals

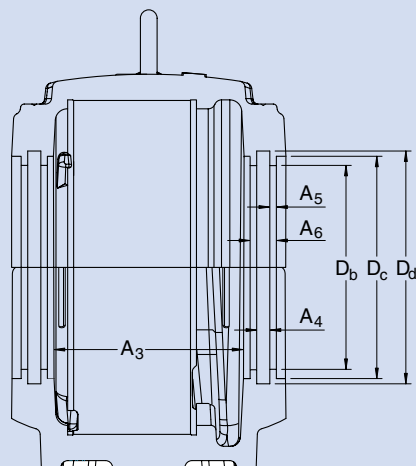

In applications where, for some reason or other, the standard seals cannot be used, special seals must be fitted. The SNL housings can be supplied without seals for such applications and are relatively easy to equip with special seals. It is recommended that housings of series SNL .. G are used rather than those of series SNL as they have a comparatively larger bore at the shaft entrance. There is therefore more room to accommodate a seal, so that there is more choice as regards seal design.

Special seals are not normally supplied by SKF. Therefore, the relevant housing dimensions are given in **Tables 2** and **3**.

Housing Size	Dimensions						
	A ₃	A ₄	A ₅	A ₆	D _b	D _c	D _d
–	mm						
SNL 3036 G	156	11	5,5	22	221,4	236,4	245,4
SNL 3038 G	166	11	5,5	22	221,4	236,4	245,4
SNL 3040 G	184	11	5,5	22	241,4	256,4	265,4
SNL 3044 G	203	11	5,5	22	261,6	276,6	285,6
SNL 3048 G	211	11	5,5	22	281,6	296,6	305,6
SNL 3052 G	228	11	5,5	22	301,6	316,8	325,6
SNL 3056 G	247	11	5,5	22	321,8	336,8	345,8
SNL 3060 G	247	11	5,5	22	341,8	356,8	365,8
SNL 3064 G	277	11	5,5	22	361,8	376,8	385,8
SNL 3068 G	295	11	5,5	22	381,8	396,8	405,8
SNL 3072 G	293	11	5,5	22	401,8	416,8	425,8
SNL 3076 G							
SNL 3080 G							
SNL 3084 G							
SNL 3088 G							
SNL 3092 G							
SNL 3096 G							
SNL 30/500 G							
SNL 3134 G	157	11	5,5	22	201,4	216,4	225,4
SNL 3136 G	166	11	5,5	22	221,4	236,4	245,4
SNL 3138 G	185	11	5,5	22	221,4	236,4	245,4
SNL 3140 G	204	11	5,5	22	241,4	256,4	265,4
SNL 3144 G	213	11	5,5	22	261,6	276,6	285,6
SNL 3148 G	230	11	5,5	22	281,6	296,6	305,6
SNL 3152 G	248	11	5,5	22	301,6	316,8	325,6
SNL 3156 G	248	11	5,5	22	321,8	336,8	345,8
SNL 3160 G	278	11	5,5	22	341,8	356,8	365,8
SNL 3164 G	297	11	5,5	22	361,8	376,8	385,8
SNL 3168 G							
SNL 3172 G							
SNL 3176 G							
SNL 3180 G							
SNL 3184 G							
SNL 3188 G							
SNL 3192 G							
SNL 3196 G							

For SNL 3076 G to SNL 30/500 G and SNL 3168 G to SNL 3196 G, inclusive, please consult SKF

Sealing groove dimensions

Table 4

Housing Size	Bearing	Dimensions			
		b_a min	b_a max ¹⁾	b_b	b_c
–		mm			
SNL 3036	23036	72	102	66,5	107,5
	24036	85	102	79,5	107,5
SNL 3038	23038	73	108	68	113,5
	24038	86	108	80,5	113,5
SNL 3040	23040	78	112	72,5	117,5
	24040	91	112	86	117,5
SNL 3044	23044	91	122	86	127,5
	24044	105	122	100	127,5
SNL 3048	23048	97	128	92	133,5
	24048	110	128	105	133,5
SNL 3052	23052	103	136	98	141,5
	24052	121	136	116	141,5
SNL 3056	23056	108	146	103	151,5
	24056	125	146	120	151,5
SNL 3060	23060	118	149	113	154,5
	24060	139	149	134	154,5
SNL 3064	23064	121	170	115,5	175,5
	24064	140	170	135	175,5
SNL 3068	23068	130	181	124,5	186,5
	24068	153	181	148	186,5
SNL 3072	23072	130	181	125	186,5
	24072	153	181	148	186,5
SNL 3076	23076				
	24076				
SNL 3080	23080				
	24080				
SNL 3084	23084				
	24084				
SNL 3088	23088				
	24088				
SNL 3092	23092				
	24092				
SNL 3096	23096				
	24096				
SNL 30/500	230/500				
	240/500				
SNL 3134	23134	78	102	73	107,5
SNL 3136	23136	83	108	78	113,5
SNL 3138	23138	88	112	83	117,5
SNL 3140	23140	93	122	88	127,5
SNL 3144	23144	100	128	95	133,5
SNL 3148	23148	106	136	101	141,5
SNL 3152	23152	116	146	111	151,5
SNL 3156	23156	119	149	114	154,5
SNL 3160	23160	138	170	133	175,5
SNL 3164	23164	149	181	144	186,5
SNL 3168	23168				
SNL 3172	23172				
SNL 3176	23176				
SNL 3180	23180				
SNL 3184	23184				
SNL 3188	23188				
SNL 3192	23192				
SNL 3196	23196				

¹⁾ For non-locating arrangements which are not mounted centrally in the bearing seating, the value of b_a max must be correspondingly reduced

For SNL 3076 to SNL 30/500 and SNL 3168 to SNL 3196, inclusive, please consult SKF

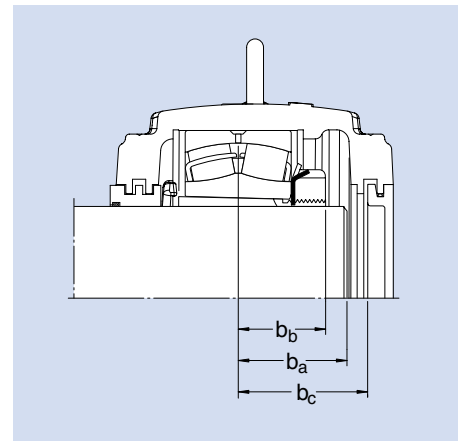
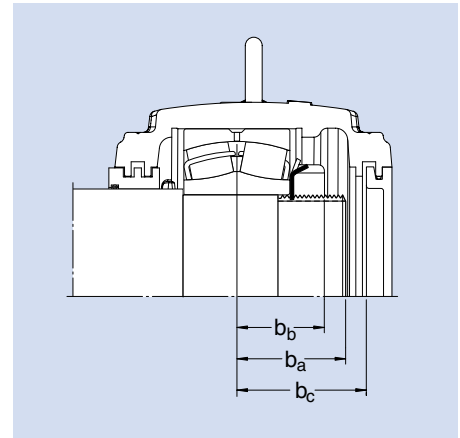

Permissible length of shaft end

End covers

For housings mounted at the ends of shafts, the one opening should be fitted with an end cover which fits into the seal groove (→ **fig 4**). Details of the permissible length of the shaft end can be found in **Table 4**. The end covers are of cast iron and are inserted with a hollow O-ring cord of silicone rubber in the seal groove in the housing. The end covers are suitable for operating temperatures in the range -50 to $+200$ °C.

The standard end cover is designated by the prefix ETS followed by the housing size identification, e.g. ETS 34. End covers for oil lubricated SNL housings are identified by suffix R, e.g. ETS 34 R.

Locating rings

The bearing seating in the housing is sufficiently wide to enable the bearing to be displaced axially. Bearings which are to locate a shaft axially in both directions (locating bearings) must always be fixed axially in position in the housing bore by locating rings at both sides (→ **fig 5**).

CARB bearings are non-locating bearings and cannot take axial loads. Since axial displacement is accommodated within a CARB bearing (together with any misalignment) it is necessary to locate the outer ring axially in its seating by inserting locating rings at each side of the bearing.

The locating rings are identified by the prefix FRB followed by figures giving the width/outside diameter in millimetres, e.g. FRB 10/280.

Housing with end cover

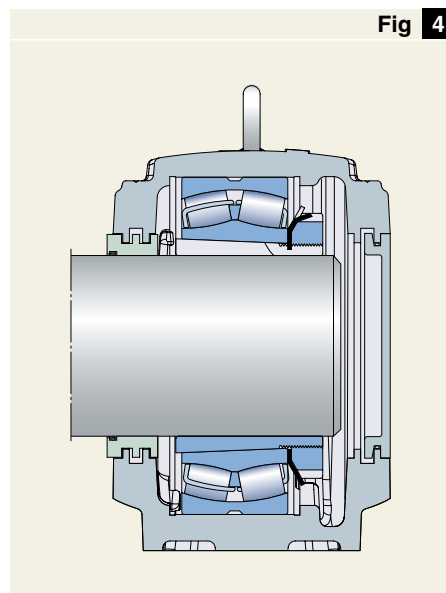

Housing with locating rings at both sides of bearing

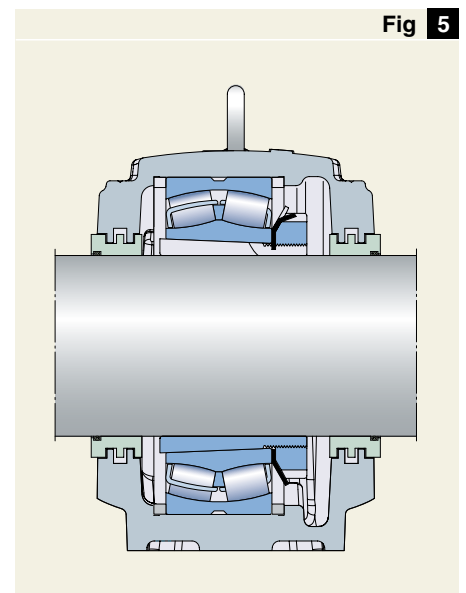

Application advice for trouble-free operation

Condition monitoring is recommended for SNL plummer blocks particularly if they are used on machines where failures would cause production stoppages. The early recognition and trending of the degradation of the machine and machine parts make it possible to analyse the cause and to be able to plan for corrective maintenance actions in good time.

Extensive monitoring experience and a knowledge of the dynamic behaviour of machines, machine components and bearings where there is incipient damage allows SKF to recommend two powerful signal processing techniques which can be used for condition monitoring.

Vibration velocity

The RMS (root mean square) of the velocity of vibrations in the frequency range 10 Hz to 1 kHz has been used with great success to measure phenomena such as imbalance, misalignment, resonance etc. High levels of velocity vibration can be generated by poor machine conditions such as improper clearances, imbalance, misalignment, weak foundations, bent rotors, out-of-round, belt problems or damaged fan blades. The ISO Standard 10816-1:1995 contains recommendations for reference values for the RMS velocity values measured on different classes of machines and machine parts. These recommendations give a clear and quantifiable measure for the changes in machine condition. Vibration velocity expressed as an overall RMS value in the 10 Hz to 1 kHz frequency range provides minimal information on defects in rolling element bearings or gear mesh problems. These types of defect can now be easily detected by enveloped acceleration in the higher frequency ranges.

Enveloped acceleration

Bearing defects can be easily recognised by measurement and analysis of an enveloped acceleration signal of

the higher frequencies generated by the impact signals typical of rolling bearing defects and gear teeth problems. This technique has proved to be



Electronic cabinet with built-in MCM™ units



Multilog on-line system



Microlog – portable data collector and analyser

extremely reliable in the detection of incipient bearing defects. The low frequencies generated by imbalance, misalignment etc. are not measured and diagnosed within the enveloped acceleration process.

- Condition monitoring and diagnosis with permanently installed monitoring systems

This type of monitoring makes it possible to check the condition using MCM™ (Mechanical Condition Monitor) for a single measuring point or the multilog LMU (Local Monitoring Unit) which sequentially monitors several measuring points. The MCM™ system should be applied where an economical solution is required (e.g. for fans). The measurement output can be directly connected to a control or DCS (Digital Control System). A relay output is also available to shut down the machine or section of the plant.

Measurement points for condition monitoring

Position 1: optimum sensor position for vertical or hanging position of bearing housing. Position 1 can be used for acceleration enveloping and also is a position identified according to ISO 10816-1.

Position 2: optimum sensor position for measurements concerning the ISO 10816-1 standard and also for acceleration enveloping for forces perpendicular to the shaft centreline.



- Condition monitoring and diagnosis with a portable data collector and analyser

In this case the condition is monitored using a portable data collector/analyser at appropriate points on the machine. Where a measurement point is difficult to access, permanently installed sensors can be used. These can be connected by cable to a connection box accessible to the data collector.

Condition monitoring of large SNL housings

SNL housings have appropriate points for sensors (→ fig 1). Measurement points 1 and 2 are perpendicular to the shaft and correspond best to ISO 10816-1:1995.

Measurement point 2 should be used on SNL housings where the load acts towards the base plate. Measurement point 1 is intended for when the housing is hung from its support or when the load acts away from the base plate.

For additional information about condition monitoring and the measurement tools and systems available from SKF please contact the SKF application engineering service.

Fig 1

Lubrication

SNL plummer block housings are so designed that the bearings in them can be lubricated with grease or oil, although grease lubrication is generally preferable. The lubricant should be selected with reference to the operating conditions. Relevant information will be found in the SKF General Catalogue and other SKF publications.

Grease lubrication

In the majority of applications, the amount of grease applied to the SNL housings when mounting (first fill) or after an inspection is adequate until the next planned inspection.

Certain operating conditions, e.g. high speeds, high temperatures or heavy loads, may mean that more frequent relubrication is necessary. **Table 1** gives guideline values for the grease quantities to be applied for the first fill and for relubrication. Markings in each corner inside the base give an indication of the grease level for the first fill (→ **fig 2**).

There are three drilled and tapped holes for a grease nipple AH 1/8-27 PTF in the housing: two in the cap and one in the base. These holes are closed by metallic plugs. The two markings at the outer sides of the central ridge indicate

Grease level markings for first fill

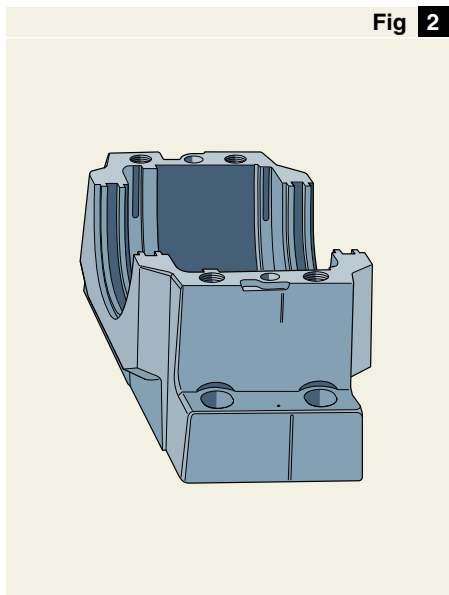

Fig 2

the position for lubrication holes for the seals.

A grease nipple AH 1/8-27 PTF is supplied with the housing. The grease nipple kit also contains a plastic grease nipple protector, a grease nipple M1 G 1/8 and an adapter LAPN 1/8. This adapter transforms the standard drilled 1/8-27 NPSF thread to a G 1/4 which enables the use of grease lubricators such as SKF SYSTEM 24.

It is recommended that spherical roller bearings having a lubrication groove and three holes in the outer ring (designation suffix W33) be lubricated via this feature (→ **fig 3**). In this case the relubrication hole in the base or in the centre of the cap should be used.

It should be noted that when spherical roller bearings are to be relubricated via the outer ring, they should be rotated. If outer ring relubrication is not possible or if CARB bearings are used the standard grease nipple supplied with the housing should be inserted in the hole on the side of the cap and used for this purpose (→ **fig 4**). If it is desired to use a grease nipple other than that supplied with the housing, adapters are available which make a reworking of the available drilled and tapped hole unnecessary.

Lubricating the bearing via the outer ring

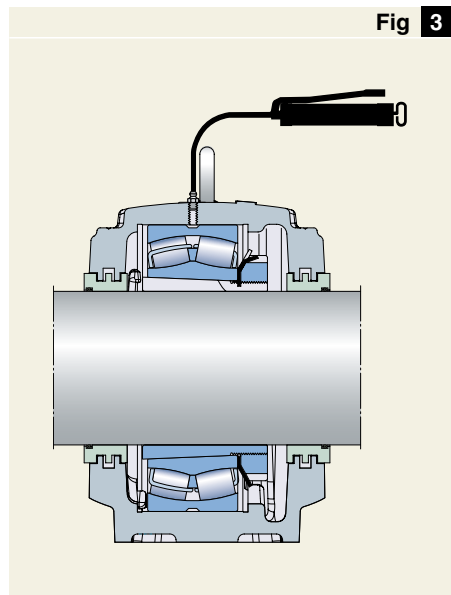

Fig 3

Grease quantities

Table 1

Housing Size	Grease quantities	
	First fill ¹⁾	Relubrication
–	kg	
SNL 3036	1,2	0,10
SNL 3038	1,5	0,11
SNL 3040	1,9	0,13
SNL 3044	2,4	0,15
SNL 3048	2,8	0,17
SNL 3052	3,6	0,21
SNL 3056	4,5	0,22
SNL 3060	4,6	0,27
SNL 3064	6,5	0,29
SNL 3068	8,1	0,35
SNL 3072	8,1	0,36
SNL 3076		
SNL 3080		
SNL 3084		
SNL 3088		
SNL 3092		
SNL 3096		
SNL 30/500		
SNL 3134	1,1	0,12
SNL 3136	1,4	0,14
SNL 3138	1,8	0,17
SNL 3140	2,3	0,19
SNL 3144	2,7	0,22
SNL 3148	3,4	0,26
SNL 3152	4,3	0,32
SNL 3156	4,4	0,34
SNL 3160	6,2	0,40
SNL 3164	7,7	0,48
SNL 3168		
SNL 3172		
SNL 3176		
SNL 3180		
SNL 3184		
SNL 3188		
SNL 3192		
SNL 3196		

¹⁾ Fills approximately 40 % of the free space in the housing

For SNL 3076 to SNL 30/500 and SNL 3168 to SNL 3196, inclusive, please consult SKF

Table 2

Recommended dimensions for grease escape hole

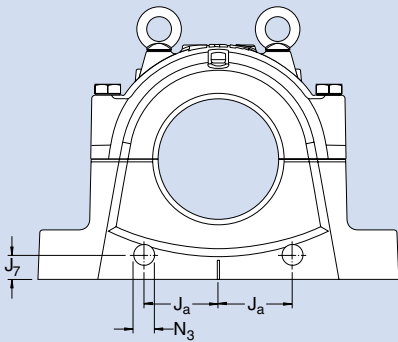

Housing Size	Dimensions		
	Ja	J7	N3
–	mm		
SNL 3036	105	34	30
SNL 3038	110	38	30
SNL 3040	120	36	30
SNL 3044	120	36	30
SNL 3048	130	42	40
SNL 3052	145	43	40
SNL 3056	150	44	40
SNL 3060	165	51	40
SNL 3064	180	53	40
SNL 3068	180	53	40
SNL 3072	180	53	40
SNL 3076			
SNL 3080			
SNL 3084			
SNL 3088			
SNL 3092			
SNL 3096			
SNL 30/500			
SNL 3134	105	34	30
SNL 3136	110	38	30
SNL 3138	120	36	30
SNL 3140	120	36	30
SNL 3144	130	42	40
SNL 3148	145	43	40
SNL 3152	150	44	40
SNL 3156	165	51	40
SNL 3160	180	53	40
SNL 3164	180	53	40
SNL 3168			
SNL 3172			
SNL 3176			
SNL 3180			
SNL 3184			
SNL 3188			
SNL 3192			
SNL 3196			

The dimensions are those recommended when the standard grease nipple AH 1/8-27 PTF is used (supplied with the housing) but can also be applied if nipples having threads R 1/8, KR 1/8, M 10×1 or G 1/4 (with adapter LAPN 1/8) are used. The recommendations also apply if grease dispensers, e.g. SKF SYSTEM 24, are used.

For SNL 3076 to SNL 30/500 and SNL 3168 to SNL 3196, inclusive, please consult SKF

2

Where the bearings are mounted on adapter sleeves, the grease should be introduced at the side opposite to the lock nut of the sleeve.

If frequent relubrication is required, it is advisable to provide the housing with grease escape holes (→ fig 5) through which excess grease can escape. Recommended dimensions will be found in Table 2. SNL housings with grease escape holes in the base can be supplied. This housing design is identified by the suffix V, e.g. SNL 3134 V.

SNL housings can also be equipped with grease lubricators. Recommended are the SKF SYSTEM 24 lubricators (e.g. LAGD 125/WA2) which provide a reliable alternative to manual relubrication.

Lubricating the bearing from the side

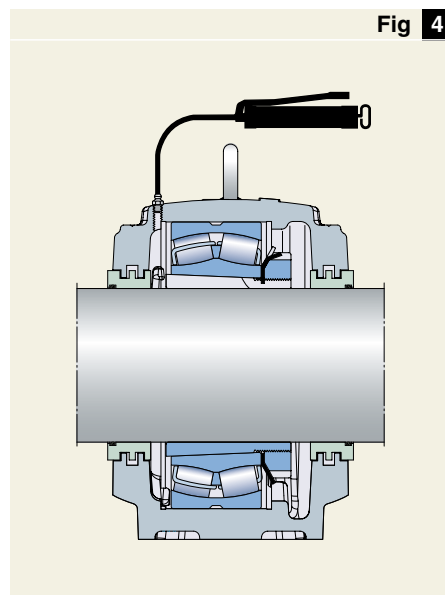

Housing with grease escape holes

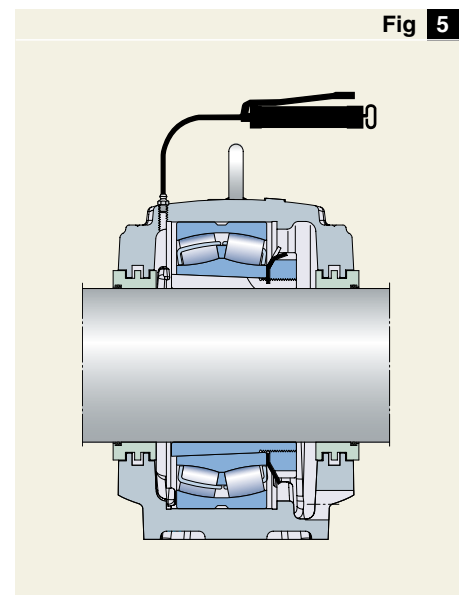

Oil lubrication

The new SNL 30 and SNL 31 housings can be used for oil lubrication at relatively high speeds. When using oil, however, the specially developed U-design seals should be incorporated to avoid oil loss from the housing (→ fig 6). These seals are described on page 14. In order for these seals to be used, the housing must be modified so that SNL housings for oil lubrication are only supplied complete with seals.

Oil lubricated SNL housings can also be equipped with oil levellers, LAHD series, which are designed for automatic adjustment of the optimal oil lubrication level within the bearing housing.

Housing for oil lubrication

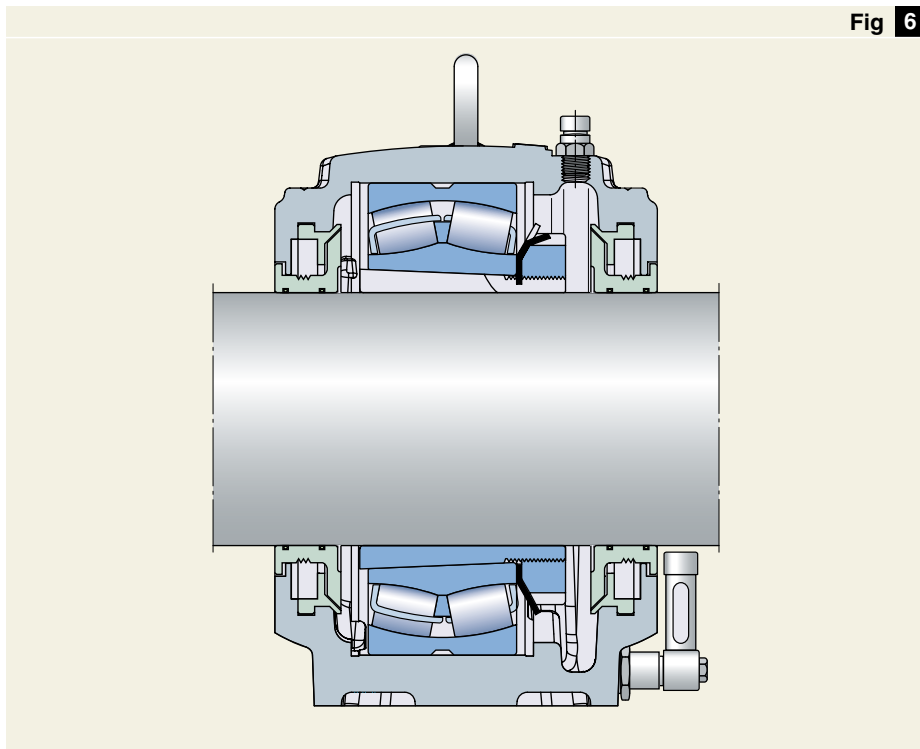

Fig 6

Mounting

SNL housings together with SKF bearings are robust and operationally reliable bearing arrangements which have long lives. However, if they are to achieve their full potential and not fail prematurely, they must be properly mounted. Incorrect procedures or unsuitable tools can influence life negatively.

When mounting the housings it should be remembered that the housings are asymmetrical internally and therefore the bearings are not always mounted in the centre of the housing.

Vertical markings on the housing base end faces indicates the location of the centre of the bearing seating.

Mounting the bearing

The bearings can be mounted either on a tapered seating – normally for SNL housings in the form of an adapter sleeve – or on a cylindrical seating. When a bearing is correctly mounted on a sleeve there will be interference fits between the inner ring, sleeve and shaft. The degree of interference is determined by how far the bearing is driven up on the sleeve and either the internal clearance reduction or the axial drive-up distance can be used as a measure. The clearance reduction in spherical roller bearings can be measured using a feeler gauge, or the SKF drive-up method can be used. Information will be sent on request.

For CARB bearings either the clearance reduction or the axial drive-up distance should be measured. When using a feeler gauge to measure clearance reduction it is important that the inner and outer rings of the bearing are not displaced with respect to each other. The SKF drive-up method can also be applied.

Adapter sleeves with the designation OH .. H in the product tables indicate that the sleeves are provided with the necessary ducts to enable the bearings to be mounted using the oil injection method. Oil is supplied to the nut side of the sleeve.

Bearings with cylindrical bore are normally mounted with an interference fit on the shaft. Appropriate shaft tolerances should be selected (→ SKF General Catalogue). The recommenda-

tions applying to spherical roller bearings also apply to CARB bearings.

Details of mounting tools as well as the SKF drive-up method can be found on the SKF CD-ROM MP282 which will be sent on request.

Support surface for housing base

To guarantee long bearing service life it is recommended that the support surface for the housing is finished to $R_a \approx 12,5 \mu\text{m}$. The flatness (planicity) tolerance should be to IT7. For moderate demands IT8 may be satisfactory.

Dowel pins

SNL housings are designed for loads acting vertically to the housing base support. If they are to be subjected to moderate or heavy loads acting parallel to the base support, a stop should be provided, or the housing should be pinned to its support. Recommendations for the position and size of holes to take dowel pins are given in **Table 3**.

Attachment bolts

It is recommended that hexagon headed bolts to strength class 8.8 according to the European Standard EN 24014 should be used. If the load does not act vertically to the base, it may be necessary to use stronger, class 10.9 bolts. Details of the appropriate tightening torques for the bolts to class 8.8 are given in **Table 2** on page 32.

Table 3

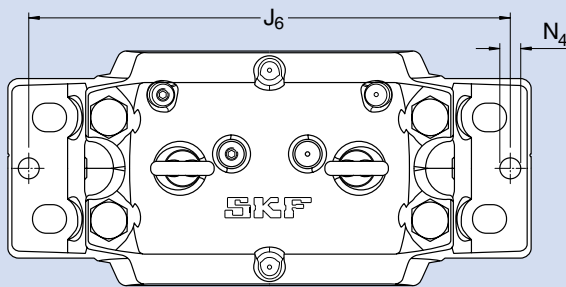

Housing Size	Dimensions		Housing Size	Dimensions	
	J ₆	N ₄ max		J ₆	N ₄ max
–	mm		–	mm	
SNL 3036	470	20	SNL 3134	470	20
SNL 3038	490	20	SNL 3136	490	20
SNL 3040	520	20	SNL 3138	520	20
SNL 3044	560	20	SNL 3140	560	20
SNL 3048	590	20	SNL 3144	590	20
SNL 3052	650	20	SNL 3148	650	20
SNL 3056	720	20	SNL 3152	720	20
SNL 3060	740	20	SNL 3156	740	20
SNL 3064	770	25	SNL 3160	770	25
SNL 3068	830	25	SNL 3164	830	25
SNL 3072	830	25	SNL 3168		
SNL 3076			SNL 3172		
SNL 3080			SNL 3176		
SNL 3084			SNL 3180		
SNL 3088			SNL 3184		
SNL 3092			SNL 3188		
SNL 3096			SNL 3192		
SNL 30/500			SNL 3196		

For SNL 3076 to SNL 30/500 and SNL 3168 to SNL 3196, inclusive, please consult SKF

Position and size of dowel pin holes

Mounting SNL 30 and SNL 31 housings with labyrinth seals

Before starting installation work, the following instructions should be carefully read.

1. Ensure that the environment is clean. Check the dimensional and form accuracy of the shaft seating.
2. Check that the surface roughness of the support surface $R_a \leq 12,5 \mu\text{m}$. The flatness (planicity) tolerance should be to IT7. For moderate demands IT8 may be satisfactory.
3. If the bearing is mounted on an adapter sleeve, determine the position of the housing. The grease nipple arranged at one side of the housing cap (for improved lubrication) should always be at the side opposite to the sleeve nut. It is necessary to consider the complete housing as the base and cap will only fit together as supplied.
4. Position the housing on the support surface. Fit the attachment bolts but do not tighten them.
5. Mount the first labyrinth seal on the shaft in the correct position.
6. Mount the bearing on the shaft – either directly on a stepped shaft or using an adapter sleeve. Completely fill the bearing with grease. The housing base should be filled with grease up to the markings in each corner inside the base (→ **Table 1**, **page 20**).
7. Mount the second labyrinth ring on the shaft in the correct position. If the housing is to be used at a shaft end, the second labyrinth ring is omitted and an end cover inserted in the housing base instead.
8. Lay the shaft with bearing and labyrinth ring(s) in the housing base.

9. Put the locating ring(s) (when needed) at each side of the bearing.

NB. Locating rings are only used for locating bearing arrangements, except for CARB bearings which, although always non-locating, must always be mounted with locating rings.

10. Carefully align the housing base. Vertical markings on the housing base ends and side faces showing the bearing seating centre can facilitate this. Then lightly tighten the attachment bolts.
11. The housing cap should be placed over the base and the cap bolts (to join cap and base) tightened to the torque specified in **Table 2** on **page 32**. The cap and base of one housing are not interchangeable with those of other housings. The cap and base should be checked to see that they bear the same consecutive number.
12. Fully tighten the attachment bolts in the housing base. Recommended tightening torques are given in **Table 2** on **page 32**.
13. Finally insert the hollow O-ring cords of synthetic rubber in the grooves in the labyrinth rings. This can be done using a screwdriver while turning the shaft.

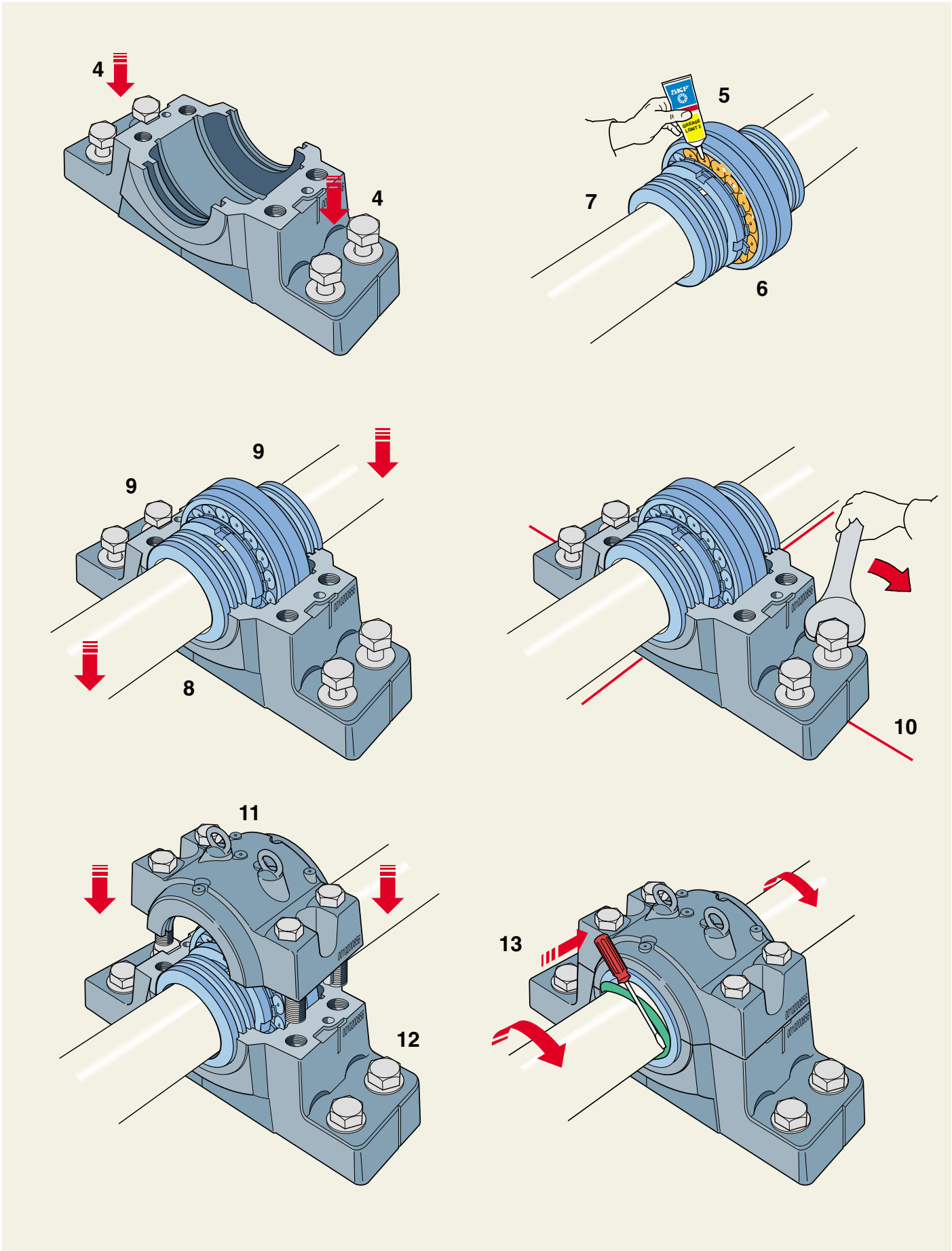

Mounting SNL 30 and SNL 31 housings with taconite seals

Before starting installation work, the following instructions should be carefully read.

1. Ensure that the environment is clean. Check the dimensional and form accuracy of the shaft seating.
2. Check that the surface roughness of the support surface $R_a \leq 12,5 \mu\text{m}$. The flatness (planicity) tolerance should be to IT7. For moderate demands IT8 may be satisfactory.
3. If the bearing is mounted on an adapter sleeve, determine the position of the housing. The grease nipple arranged at one side of the housing cap (for improved lubrication) should always be at the side opposite to the sleeve nut. It is necessary to consider the complete housing as the base and cap will only fit together as supplied.
4. Position the housing on the support surface. Fit the attachment bolts but do not tighten them.
5. Slide the parts for the first seal to the correct position on the shaft. The lip of the V-ring should point towards the bearing. Do not tighten the grub screws.
6. Mount the bearing on the shaft – either directly on a stepped shaft or using an adapter sleeve. Completely fill the bearing with grease. The housing base should be filled with grease up to the markings in each corner inside the base (→ **Table 1**, **page 20**).
7. Mount the second seal according to point 5. If the housing is to be used at a shaft end, the second seal is omitted and an end cover inserted in the housing base instead.
8. Check that the O-ring is in the correct position on the seal outside diameter.

9. Lay the shaft with bearing and seals in the housing base taking care that the O-rings are not damaged.

10. Put the locating ring(s) (when needed) at each side of the bearing.

NB. Locating rings are only used for locating bearing arrangements, except for CARB bearings which, although always non-locating, must always be mounted with locating rings.

11. Carefully align the housing base. Vertical markings on the housing base ends and side faces showing the bearing seating centre can facilitate this. Then lightly tighten the attachment bolts.

12. The housing cap should be placed over the base, taking care that the O-rings are not damaged, and the cap bolts (to join cap and base) tightened to the torque specified in **Table 2** on **page 32**. The cap and base of one housing are not interchangeable with those of other housings. The cap and base should be checked to see that they bear the same consecutive number.

13. Fully tighten the attachment bolts in the housing base. Recommended tightening torques are given in **Table 2** on **page 32**.

14. Adjust the flingers to the correct position and tighten the grub screws. The clearance in the seal must exceed the axial movement of the bearing.

15. Finally, before the first test run, rotate the shaft and supply grease via the nipple until it exudes from the labyrinth rings. The same grease as that used for the bearing should also be used to lubricate the labyrinth rings.

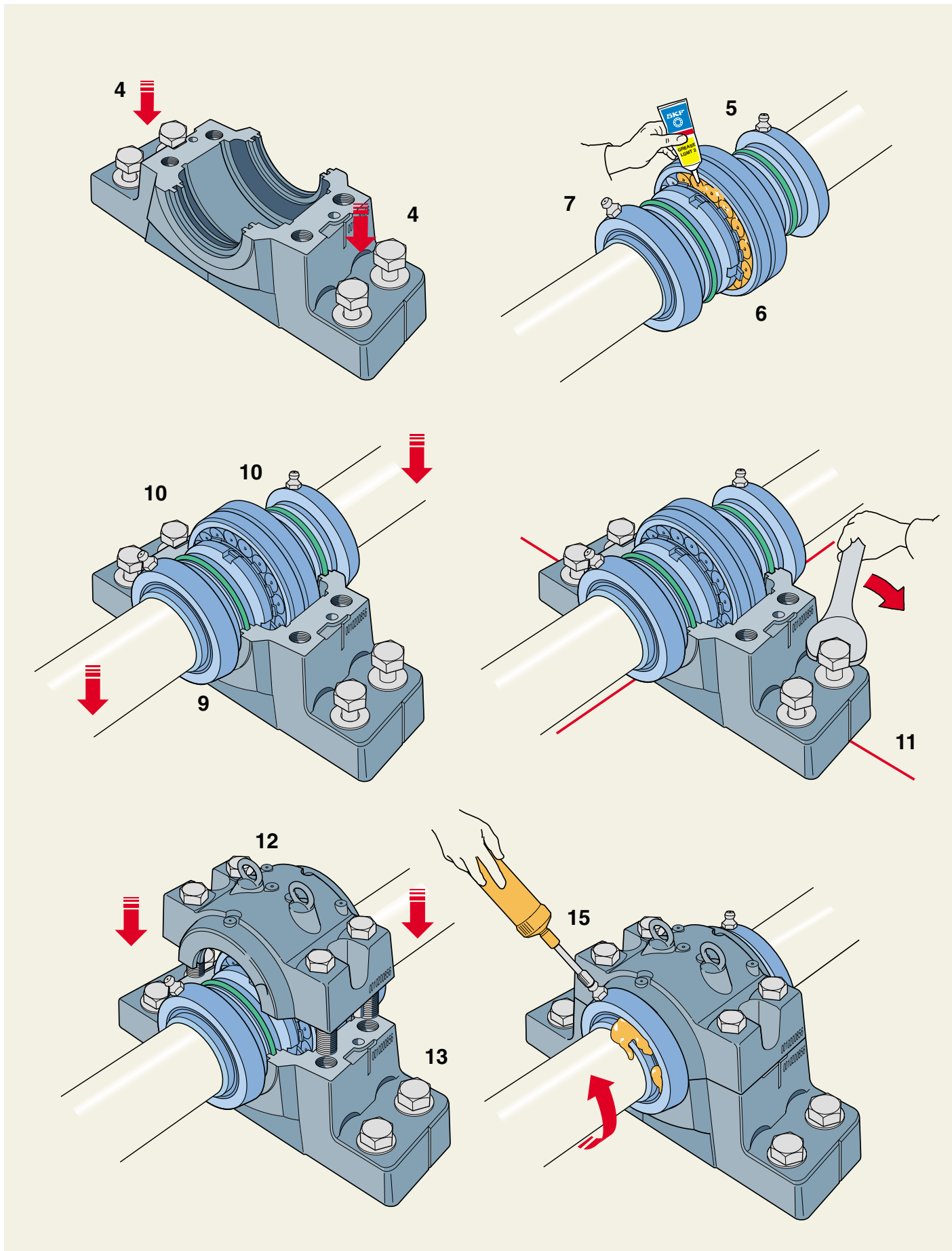

Mounting SNL 30 and SNL 31 housings with oil seals

Before starting installation work, the following instructions should be carefully read.

1. Ensure that the environment is clean. Check the dimensional and form accuracy of the shaft seating.

2. Check that the surface roughness of the support surface $R_a \leq 12,5 \mu\text{m}$. The flatness (planicity) tolerance should be to IT7. For moderate demands IT8 may be satisfactory.

3. If the bearing is mounted on an adapter sleeve, determine the position of the housing. It is necessary to consider the complete housing as the base and cap will only fit together as supplied.

4. Position the housing on the support surface. Fit the attachment bolts but do not tighten them.

5. Cover the shaft with a thin layer of oil. Slide the parts for the first seal to the correct position on the shaft.

6. Mount the bearing on the shaft – either directly on a stepped shaft or using an adapter sleeve.

7. Slide the parts for the second seal to the correct position on the shaft. Keep the locating pin in the outer seal parts in a horizontal position.

8. Lay the shaft with bearing and seal parts in the housing base.

9. Put the locating ring(s) (when needed) at each side of the bearing.

NB. Locating rings are only used for locating bearing arrangements, except for CARB bearings which, although always non-locating, must be mounted with locating rings.

10. Carefully align the housing base. Vertical markings on the housing base ends and side faces showing the bearing seating centre can facilitate this. Then lightly tighten the attachment bolts.

11. Cover the mating surfaces of the housing with oil-resistant sealant, place the housing cap over the base and tighten the cap bolts to the torque specified in **Table 2** on **page 32**. The cap and base of one housing are not interchangeable with those of other housings. The cap and base should be checked to see that they bear the same consecutive number.

12. Fully tighten the attachment bolts in the housing base. Recommended tightening torques are given in **Table 2** on **page 32**.

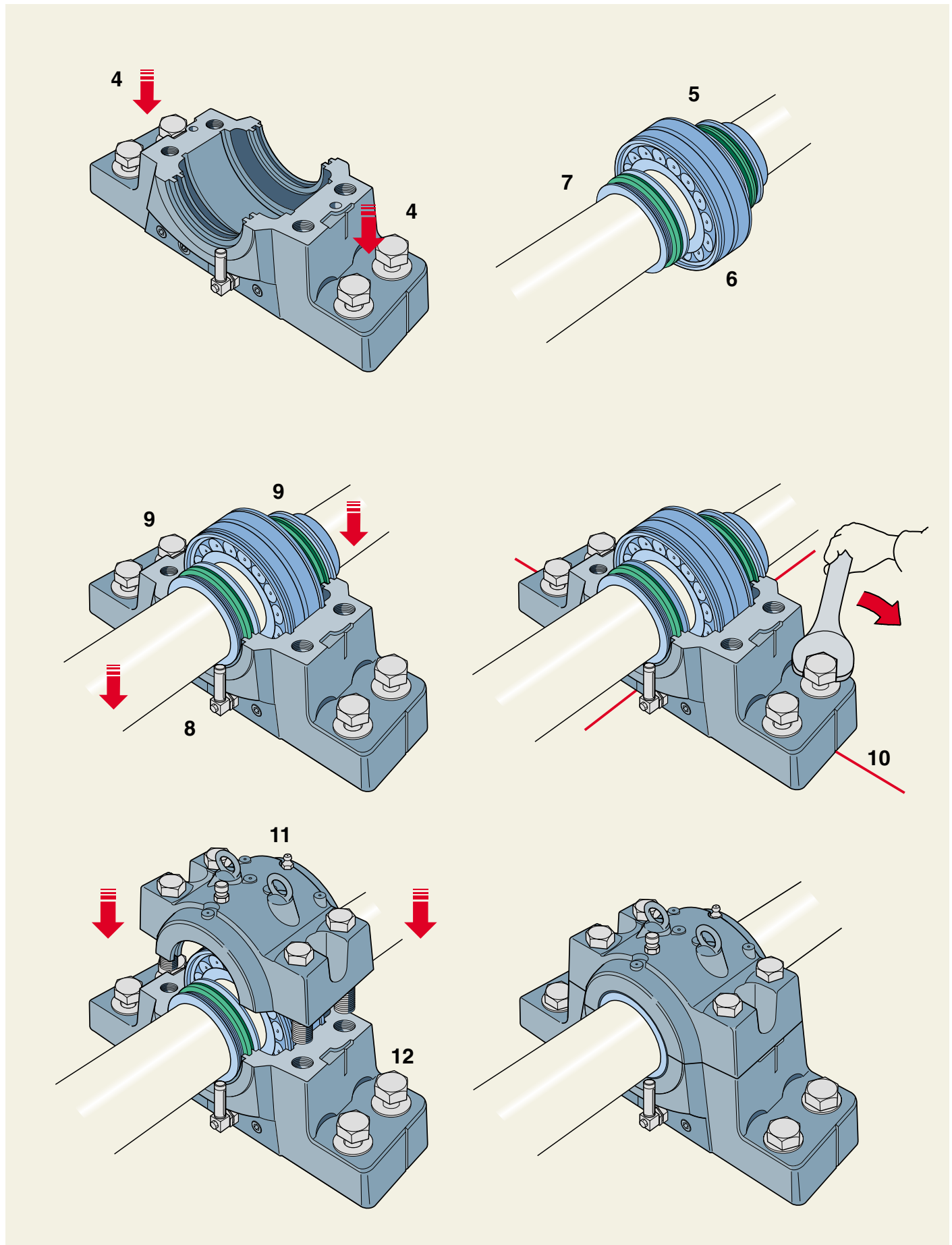

Designations and housing data

Designations

The designations used for SNL housings consist of a basic designation which identifies the design, material and size followed by any supplementary design-

nations needed to identify features which differ from the standard design. A dash (-) in the chart indicates that the feature belongs to the standard design.

Designation chart

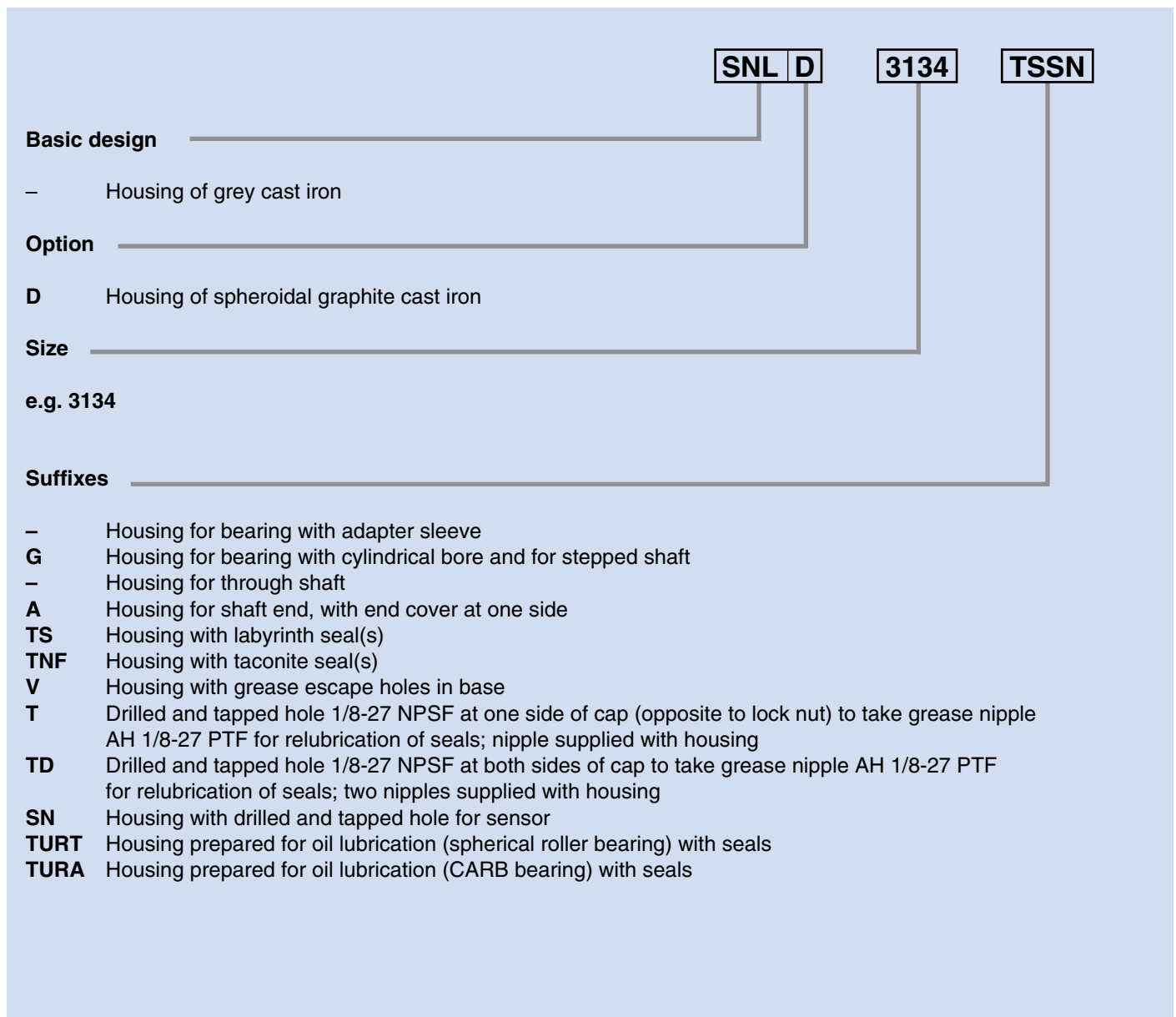

Load carrying ability

SNL plummer block housings are intended for loads acting vertically towards the base plate (support). If loads acting in other directions occur, checks should be made to ensure that the magnitude of the load is permissible for the housing, the bolts joining the housing cap and base, and for the attachment bolts.

Load carrying ability of the housing

Guideline values for the breaking load P of the housing for various load directions are given in **Table 1**. Using these values and a safety factor selected with respect to the operating conditions, the permissible load for the housing can be calculated. In general engineering a safety factor of 6 is often used.

For special purposes where extra strength and resistance to shock loads are required, SKF supplies as standard a range of spheroidal graphite cast iron housings. Spheroidal graphite cast iron housings are designated SNLD followed by the size identification, e.g. SNLD 3134. For housings made of spheroidal graphite cast iron the values of P in **Table 1** should be multiplied by 1,8.

It is important for the load carrying ability of the housing that the bolts joining cap and base are properly tightened in accordance with the values given in **Table 2**. The axial load carrying capacity of the housing is approximately 65 % of P_{180° . For load angles between 55 and 120° as well as for axial loads, if the load acting parallel to the base plate (support surface) exceeds 5 % of P_{180° , the housing should be pinned to the support or a stop should be provided in the direction of the load.

Breaking loads for SNL plummer block housings

Table 1

Housing Size	Breaking loads for SNL housing					
	P_{55°	P_{90°	P_{120°	P_{150°	P_{180°	P_a
–	kN					
SNL 3036	2 100	1 000	760	680	850	550
SNL 3038	2 400	1 150	850	760	950	620
SNL 3040	2 700	1 300	1 000	880	1 100	710
SNL 3044	3 200	1 600	1 100	1 000	1 300	840
SNL 3048	4 000	1 900	1 400	1 300	1 600	1 000
SNL 3052	4 200	2 000	1 500	1 400	1 700	1 100
SNL 3056	4 700	2 300	1 700	1 500	1 900	1 200
SNL 3060	5 000	2 400	1 800	1 600	2 000	1 300
SNL 3064	6 000	2 900	2 200	1 900	2 400	1 500
SNL 3068	7 000	3 400	2 500	2 200	2 800	1 800
SNL 3072	7 000	3 400	2 500	2 200	2 800	1 800
SNL 3076						
SNL 3080						
SNL 3084						
SNL 3088						
SNL 3092						
SNL 3096						
SNL 30/500						
SNL 3134	2 100	1 000	760	680	850	550
SNL 3136	2 400	1 150	850	760	950	620
SNL 3138	2 700	1 300	1 000	880	1 100	710
SNL 3140	3 200	1 600	1 100	1 000	1 300	840
SNL 3144	4 000	1 900	1 400	1 300	1 600	1 000
SNL 3148	4 200	2 000	1 500	1 400	1 700	1 100
SNL 3152	4 700	2 300	1 700	1 500	1 900	1 200
SNL 3156	5 000	2 400	1 800	1 600	2 000	1 300
SNL 3160	6 000	2 900	2 200	1 900	2 400	1 500
SNL 3164	7 000	3 400	2 500	2 200	2 800	1 800
SNL 3168						
SNL 3172						
SNL 3176						
SNL 3180						
SNL 3184						
SNL 3188						
SNL 3192						
SNL 3196						

For SNL 3076 to SNL 30/500 and SNL 3168 to SNL 3196, inclusive, please consult SKF

Table 2

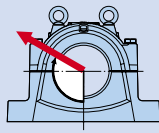

Q_{120°}
F_{120°}

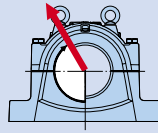

Q_{150°}
F_{150°}

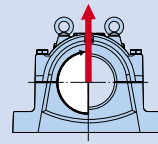

Q_{180°}
F_{180°}

Housing Size	Cap bolts Yield point for four bolts			Maximum load for four bolts			Tightening torque	Designation to EN 24014	Attachment bolts	
	Q _{120°}	Q _{150°}	Q _{180°}	F _{120°}	F _{150°}	F _{180°}			Size	Tightening torque
–	kN			kN			Nm	–	–	Nm
SNL 3036	1 800	1 040	900	760	440	380	350	M 24×140	M 24	750
SNL 3038	1 800	1 040	900	760	440	380	350	M 24×140	M 24	750
SNL 3040	1 800	1 040	900	760	440	380	350	M 24×150	M 24	750
SNL 3044	1 800	1 040	900	760	440	380	350	M 24×160	M 30	1 400
SNL 3048	1 800	1 040	900	760	440	380	350	M 24×160	M 30	1 400
SNL 3052	2 860	1 650	1 430	1 240	720	620	400	M 30×180	M 30	1 400
SNL 3056	2 860	1 650	1 430	1 240	720	620	400	M 30×200	M 36	2 400
SNL 3060	2 860	1 650	1 430	1 240	720	620	400	M 30×200	M 36	2 400
SNL 3064	2 860	1 650	1 430	1 240	720	620	400	M 30×220	M 36	2 400
SNL 3068	2 860	1 650	1 430	1 240	720	620	400	M 30×220	M 36	2 400
SNL 3072	2 860	1 650	1 430	1 240	720	620	400	M 30×220	M 36	2 400
SNL 3076										
SNL 3080										
SNL 3084										
SNL 3088										
SNL 3092										
SNL 3096										
SNL 30/500										
SNL 3134	1 800	1 040	900	760	440	380	350	M 24×140	M 24	750
SNL 3136	1 800	1 040	900	760	440	380	350	M 24×140	M 24	750
SNL 3138	1 800	1 040	900	760	440	380	350	M 24×150	M 24	750
SNL 3140	1 800	1 040	900	760	440	380	350	M 24×160	M 30	1 400
SNL 3144	1 800	1 040	900	760	440	380	350	M 24×160	M 30	1 400
SNL 3148	2 860	1 650	1 430	1 240	720	620	400	M 30×180	M 30	1 400
SNL 3152	2 860	1 650	1 430	1 240	720	620	400	M 30×200	M 36	2 400
SNL 3156	2 860	1 650	1 430	1 240	720	620	400	M 30×200	M 36	2 400
SNL 3160	2 860	1 650	1 430	1 240	720	620	400	M 30×220	M 36	2 400
SNL 3164	2 860	1 650	1 430	1 240	720	620	400	M 30×220	M 36	2 400
SNL 3168										
SNL 3172										
SNL 3176										
SNL 3180										
SNL 3184										
SNL 3188										
SNL 3192										
SNL 3196										

For SNL 3076 to SNL 30/500 and SNL 3168 to SNL 3196, inclusive, please consult SKF

Load carrying ability of bolts

SNL plummer block housings are supplied with cap bolts (to join cap and base) to strength class 8.8 as standard. The guideline values for the yield point Q for the cap bolts are given in **Table 2** for various load directions as well as the corresponding maximum radial loads F.

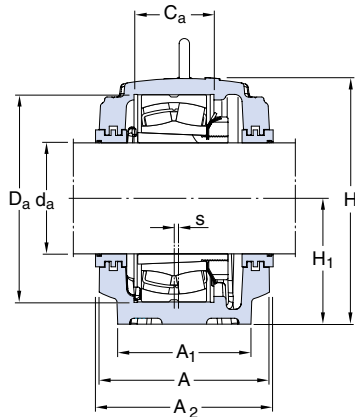

Labyrinth seals
TS design

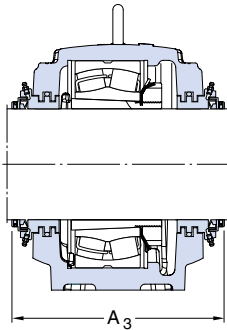

Taconite seals
TNF design

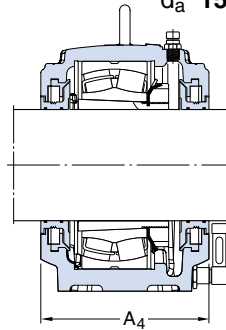

Oil seals
TSD .. U design

Shaft d _a	Housing Dimensions												Mass kg	Designations Housing complete with two seals	Components Housing only	Seal	End cover
	A	A ₁	H	H ₁	H ₂	J	J ₁	L	N	N ₁	s	G					
mm	mm												kg	–			
150	230	180	333	170	70	430	100	510	34	28	14	24	69,5	SNL 3134 TS	SNL 3134	TS 34	ETS 34
														SNL 3134 TNF	SNL 3134	TNF 34	ETS 34
														SNL 3134 TURT	–	TSD 3134 U	ETS 34 R
														SNL 3134 TURA	–	TSD 3134 U	ETS 34 R
160	230	180	333	170	70	430	100	510	34	28	14	24	69,5	SNL 3036 TS	SNL 3036	TS 36	ETS 36
														SNL 3036 TNF	SNL 3036	TNF 36	ETS 36
														SNL 3036 TURT	–	TSD 3036 U	ETS 36 R
														SNL 3036 TURA	–	TSD 3036 U	ETS 36 R
170	240	190	353	180	75	450	110	530	34	28	15	24	77,5	SNL 3136 TS	SNL 3136	TS 36	ETS 36
														SNL 3136 TNF	SNL 3136	TNF 36	ETS 36
														SNL 3136 TURT	–	TSD 3136 U	ETS 36 R
														SNL 3136 TURA	–	TSD 3136 U	ETS 36 R
180	240	190	353	180	75	450	110	530	34	28	15	24	77,5	SNL 3038 TS	SNL 3038	TS 38	ETS 38
														SNL 3038 TNF	SNL 3038	TNF 38	ETS 38
														SNL 3038 TURT	–	TSD 3038 U	ETS 38 R
														SNL 3038 TURA	–	TSD 3038 U	ETS 38 R
180	260	210	375	190	80	480	120	560	34	28	10	24	97,5	SNL 3138 TS	SNL 3138	TS 38	ETS 38
														SNL 3138 TNF	SNL 3138	TNF 38	ETS 38
														SNL 3138 TURT	–	TSD 3138 U	ETS 38 R
														SNL 3138 TURA	–	TSD 3138 U	ETS 38 R
180	260	210	375	190	80	480	120	560	34	28	10	24	97,5	SNL 3040 TS	SNL 3040	TS 40	ETS 40
														SNL 3040 TNF	SNL 3040	TNF 40	ETS 40
														SNL 3040 TURT	–	TSD 3040 U	ETS 40 R
														SNL 3040 TURA	–	TSD 3040 U	ETS 40 R
180	280	230	411	210	85	510	130	610	42	35	10	30	123	SNL 3140 TS	SNL 3140	TS 40	ETS 40
														SNL 3140 TNF	SNL 3140	TNF 40	ETS 40
														SNL 3140 TURT	–	TSD 3140 U	ETS 40 R
														SNL 3140 TURA	–	TSD 3140 U	ETS 40 R
200	280	230	411	210	85	510	130	610	42	35	10	30	123	SNL 3044 TS	SNL 3044	TS 44	ETS 44
														SNL 3044 TNF	SNL 3044	TNF 44	ETS 44
														SNL 3044 TURT	–	TSD 3044 U	ETS 44 R
														SNL 3044 TURA	–	TSD 3044 U	ETS 44 R
200	290	240	434	220	90	540	140	640	42	35	12	30	138	SNL 3144 TS	SNL 3144	TS 44	ETS 44
														SNL 3144 TNF	SNL 3144	TNF 44	ETS 44
														SNL 3144 TURT	–	TSD 3144 U	ETS 44 R
														SNL 3144 TURA	–	TSD 3144 U	ETS 44 R

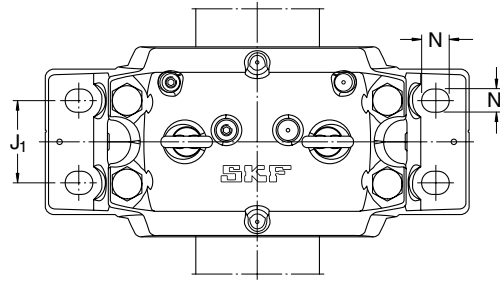
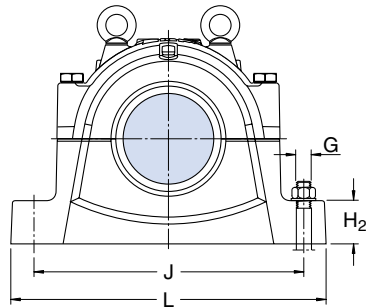

Shaft d_a	Bearing seating		Width across seals			Eye bolts according to DIN 580	Appropriate bearings and associated components		
	C_a	D_a	A_2	A_3	A_4		Spherical roller bearing CARB bearing	Adapter sleeve	Locating rings
mm	mm	mm	mm	mm	mm	—	—	—	—
150	108	280	240	300	226	M 16	23134 CCK/W33	H 3134	2 FRB 10/280
160	108	280	240	310	226	M 16	23036 CCK/W33 C 3036 K	H 3036 H 3036	2 FRB 17/280 2 FRB 17/280
	116	300	250	315	235	M 16	23136 CCK/W33 C 3136 K	H 3136 H 3136 L	2 FRB 10/300 2 FRB 10/300
170	115	290	250	315	235	M 16	23038 CCK/W33 C 3038 K	H 3038 H 3038	4 FRB 10/290 4 FRB 10/290
	124	320	270	335	255	M 20	23138 CCK/W33	H 3138	2 FRB 10/320
180	122	310	270	335	255	M 20	23040 CCK/W33 C 3040 K	H 3040 H 3040	4 FRB 10/310 4 FRB 10/310
	132	340	290	355	274	M 20	23140 CCK/W33 C 3140 K	H 3140 H 3140	2 FRB 10/340 2 FRB 10/340
200	130	340	290	360	274	M 20	23044 CCK/W33 C 3044 K	OH 3044 H OH 3044 H	4 FRB 10/340 4 FRB 10/340
	140	370	300	365	280	M 20	23144 CCK/W33 C 3144 K	OH 3144 H OH 3144 HTL	2 FRB 10/370 2 FRB 10/370

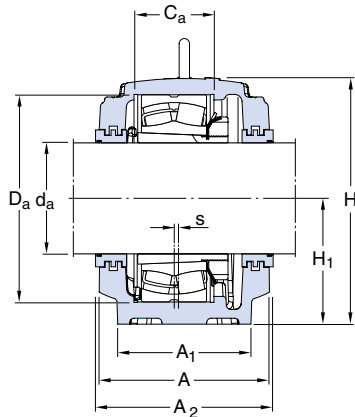

Labyrinth seals
TS design

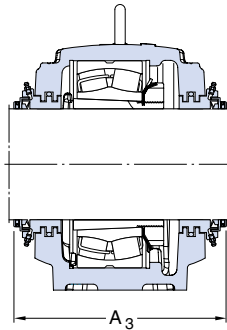

Taconite seals
TNF design

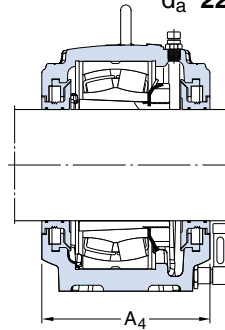

Oil seals
TSD .. U design

Shaft d _a	Housing Dimensions												Mass kg	Designations Housing complete with two seals	Components Housing only	Seal	End cover
	A	A ₁	H	H ₁	H ₂	J	J ₁	L	N	N ₁	s	G					
mm	mm												kg	–			
220	290	240	434	220	90	540	140	640	42	35	12	30	139	SNL 3048 TS SNL 3048 TNF SNL 3048 TURT SNL 3048 TURA	SNL 3048 SNL 3048 – –	TS 48 TNF 48 TSD 3048 U TSD 3048 U	ETS 48 ETS 48 ETS 48 R ETS 48 R
	310	260	474	240	95	600	150	700	42	35	12	30	187	SNL 3148 TS SNL 3148 TNF SNL 3148 TURT SNL 3148 TURA	SNL 3148 SNL 3148 – –	TS 48 TNF 48 TSD 3148 U TSD 3148 U	ETS 48 ETS 48 ETS 48 R ETS 48 R
240	310	260	474	240	95	600	150	700	42	35	12	30	187	SNL 3052 TS SNL 3052 TNF SNL 3052 TURT SNL 3052 TURA	SNL 3052 SNL 3052 – –	TS 52 TNF 52 TSD 3052 U TSD 3052 U	ETS 52 ETS 52 ETS 52 R ETS 52 R
	320	280	516	260	100	650	160	770	50	42	13	36	221	SNL 3152 TS SNL 3152 TNF SNL 3152 TURT SNL 3152 TURA	SNL 3152 SNL 3152 – –	TS 52 TNF 52 TSD 3152 U TSD 3152 U	ETS 52 ETS 52 ETS 52 R ETS 52 R
260	320	280	516	260	100	650	160	770	50	42	13	36	221	SNL 3056 TS SNL 3056 TNF SNL 3056 TURT SNL 3056 TURA	SNL 3056 SNL 3056 – –	TS 56 TNF 56 TSD 3056 U TSD 3056 U	ETS 56 ETS 56 ETS 56 R ETS 56 R
	320	280	551	280	105	670	160	790	50	42	16	36	252	SNL 3156 TS SNL 3156 TNF SNL 3156 TURT SNL 3156 TURA	SNL 3156 SNL 3156 – –	TS 56 TNF 56 TSD 3156 U TSD 3156 U	ETS 56 ETS 56 ETS 56 R ETS 56 R
280	320	280	551	280	105	670	160	790	50	42	16	36	252	SNL 3060 TS SNL 3060 TNF SNL 3060 TURT SNL 3060 TURA	SNL 3060 SNL 3060 – –	TS 60 TNF 60 TSD 3060 U TSD 3060 U	ETS 60 ETS 60 ETS 60 R ETS 60 R
	350	310	591	300	110	710	190	830	50	42	22	36	301	SNL 3160 TS SNL 3160 TNF SNL 3160 TURT SNL 3160 TURA	SNL 3160 SNL 3160 – –	TS 60 TNF 60 TSD 3160 U TSD 3160 U	ETS 60 ETS 60 ETS 60 R ETS 60 R
300	350	310	591	300	110	710	190	830	50	42	22	36	301	SNL 3064 TS SNL 3064 TNF SNL 3064 TURT SNL 3064 TURA	SNL 3064 SNL 3064 – –	TS 64 TNF 64 TSD 3064 U TSD 3064 U	ETS 64 ETS 64 ETS 64 R ETS 64 R
	370	330	631	320	115	750	200	880	50	42	23	36	339	SNL 3164 TS SNL 3164 TNF SNL 3164 TURT SNL 3164 TURA	SNL 3164 SNL 3164 – –	TS 64 TNF 64 TSD 3164 U TSD 3164 U	ETS 64 ETS 64 ETS 64 R ETS 64 R

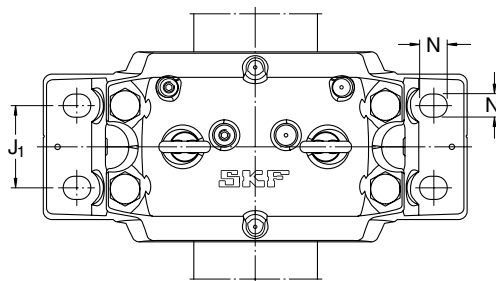
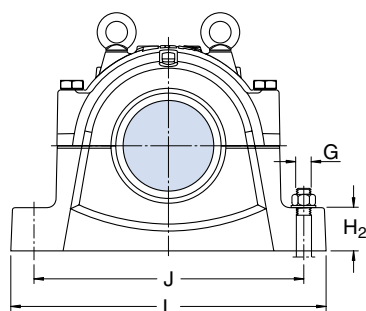

Shaft d_a	Bearing seating		Width across seals			Eye bolts according to DIN 580	Appropriate bearings and associated components		
	C_a	D_a	A_2	A_3	A_4		Spherical roller bearing CARB bearing	Adapter sleeve	Locating rings
mm	mm	mm	mm	mm	mm	—	—	—	—
220	140	360	300	380	280	M 20	23048 CCK/W33 C 3048 K	OH 3048 H OH 3048 H	4 FRB 12/360 4 FRB 12/360
	148	400	315	400	300	M 24	23148 CCK/W33 C 3148 K	OH 3148 H OH 3148 HTL	2 FRB 10/400 2 FRB 10/400
240	148	400	315	400	300	M 24	23052 CCK/W33 C 3052 K	OH 3052 H OH 3052 H	2 FRB 22/400 2 FRB 22/400
	164	440	330	415	315	M 24	23152 CCK/W33 C 3152 K	OH 3152 H OH 3152 HTL	2 FRB 10/440 2 FRB 10/440
260	166	420	330	415	315	M 24	23056 CCK/W33 C 3056 K	OH 3056 H OH 3056 H	6 FRB 10/420 6 FRB 10/420
	166	460	330	415	315	M 24	23156 CCK/W33 C 3156 K	OH 3156 H OH 3156 HTL	2 FRB 10/460 2 FRB 10/460
280	168	460	330	415	315	M 24	23060 CCK/W33 C 3060 K	OH 3060 H OH 3060 H	2 FRB 25/460 2 FRB 25/460
	180	500	360	445	345	M 30	23160 CCK/W33 C 3160 K	OH 3160 H OH 3160 H	2 FRB 10/500 2 FRB 10/500
300	181	480	360	445	345	M 30	23064 CCK/W33 C 3064 K	OH 3064 H OH 3064 H	6 FRB 10/480 6 FRB 10/480
	196	540	380	465	365	M 30	23164 CCK/W33 C 3164 K	OH 3164 H OH 3164 H	2 FRB 10/540 2 FRB 10/540

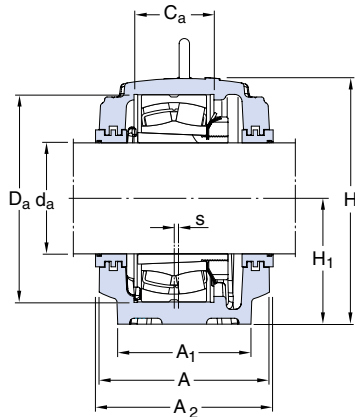

Labyrinth seals
TS design

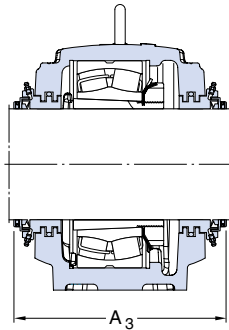

Taconite seals
TNF design

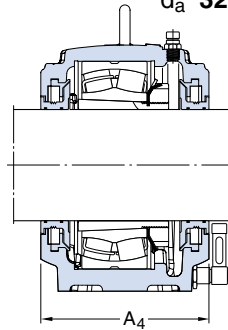

Oil seals
TSD .. U design

Shaft d _a	Housing Dimensions												Mass	Designations Housing complete with two seals	Components Housing only	Seal	End cover
	A	A ₁	H	H ₁	H ₂	J	J ₁	L	N	N ₁	s	G					
mm	mm												kg	–			
320	370	330	631	320	115	750	200	880	50	42	23	36	339	SNL 3068 TS SNL 3068 TNF SNL 3068 TURT SNL 3068 TURA	SNL 3068 SNL 3068 – –	TS 68 TNF 68 TSD 3068 U TSD 3068 U	ETS 68 ETS 68 ETS 68 R ETS 68 R
					340	810	220							SNL 3168 TS SNL 3168 TNF SNL 3168 TURT SNL 3168 TURA	SNL 3168 SNL 3168 – –	TS 68 TNF 68 TSD 3168 U TSD 3168 U	ETS 68 ETS 68 ETS 68 R ETS 68 R
340	370	330	631	320	115	750	200	880	50	42	23	36	339	SNL 3072 TNF SNL 3072 TNF SNL 3072 TURT SNL 3072 TURA	SNL 3072 SNL 3072 – –	TS 72 TNF 72 TSD 3072 U TSD 3072 U	ETS 72 ETS 72 ETS 72 R ETS 72 R
					350	840	220							SNL 3172 TS SNL 3172 TNF SNL 3172 TURT SNL 3172 TURA	SNL 3172 SNL 3172 – –	TS 72 TNF 72 TSD 3172 U TSD 3172 U	ETS 72 ETS 72 ETS 72 R ETS 72 R
360				340	810	220								SNL 3076 TS SNL 3076 TNF SNL 3076 TURT SNL 3076 TURA	SNL 3076 SNL 3076 – –	TS 76 TNF 76 TSD 3076 U TSD 3076 U	ETS 76 ETS 76 ETS 76 R ETS 76 R
				360	870	220								SNL 3176 TS SNL 3176 TNF SNL 3176 TURT SNL 3176 TURA	SNL 3176 SNL 3176 – –	TS 76 TNF 76 TSD 3176 U TSD 3176 U	ETS 76 ETS 76 ETS 76 R ETS 76 R
380				350	840	220								SNL 3080 TS SNL 3080 TNF SNL 3080 TURT SNL 3080 TURA	SNL 3080 SNL 3080 – –	TS 80 TNF 80 TSD 3080 U TSD 3080 U	ETS 80 ETS 80 ETS 80 R ETS 80 R
				380	950	240								SNL 3180 TS SNL 3180 TNF SNL 3180 TURT SNL 3180 TURA	SNL 3180 SNL 3180 – –	TS 80 TNF 80 TSD 3180 U TSD 3180 U	ETS 80 ETS 80 ETS 80 R ETS 80 R
400				360	870	220								SNL 3084 TS SNL 3084 TNF SNL 3084 TURT SNL 3084 TURA	SNL 3084 SNL 3084 – –	TS 84 TNF 84 TSD 3084 U TSD 3084 U	ETS 84 ETS 84 ETS 84 R ETS 84 R
				410	1 000	260								SNL 3184 TS SNL 3184 TNF SNL 3184 TURT SNL 3184 TURA	SNL 3184 SNL 3184 – –	TS 84 TNF 84 TSD 3184 U TSD 3184 U	ETS 84 ETS 84 ETS 84 R ETS 84 R

For missing dimensions and availability please consult SKF

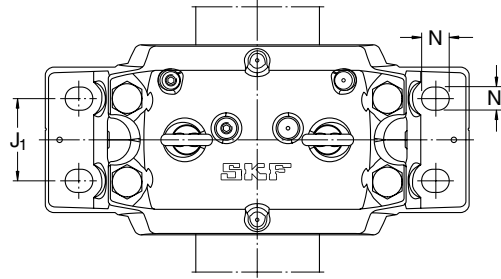
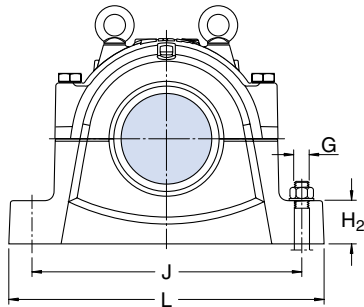

Shaft d_a	Bearing seating		Width across seals			Eye bolts according to DIN 580	Appropriate bearings and associated components		
	C_a	D_a	A_2	A_3	A_4		Spherical roller bearing CARB bearing	Adapter sleeve	Locating rings
mm	mm	mm	mm	mm	mm	—	—	—	—
320	197	520	380	465	365	M 30	23068 CCK/W33 C 3068 KM	OH 3068 H OH 3068 H	4 FRB 16/520 4 FRB 16/520
		580					23168 CCK/W33 C 3168 KM	OH 3168 H OH 3168 H	
340	198	540	380	465	365	M 30	23072 CCK/W33	OH 3072 H	4 FRB 16/540
		600					23172 CCK/W33 C 3172 KM	OH 3172 H OH 3172 H	
360	560						23076 CCK/W33	OH 3076 H	
		620				23176 CAK/W33	OH 3176 H		
380	600						23080 CCK/W33 C 3080 KM	OH 3080 H OH 3080 H	
		650				23180 CAK/W33 C 3180 KM	OH 3180 H OH 3180 H		
400	620						23084 CAK/W33	OH 3084 H	
		700				23184 CKJ/W33	OH 3184 H		

For missing dimensions and availability please consult SKF

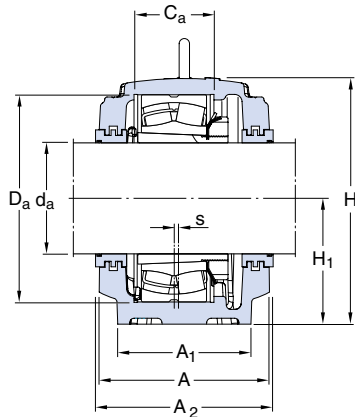

Labyrinth seals
TS design

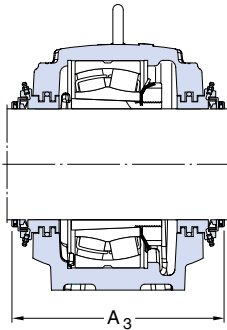

Taconite seals
TNF design

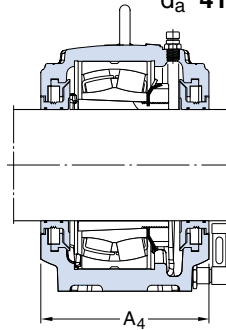

Oil seals
TSD .. U design

Shaft d _a	Housing Dimensions						Mass	Designations Housing complete with two seals	Components		End cover				
	A	A ₁	H	H ₁	H ₂	J			J ₁	L		N	N ₁	s	G
mm	mm						kg	–							
410			380		950	240		SNL 3088 TS	SNL 3088	TS 88	ETS 88				
								SNL 3088 TNF	SNL 3088	TNF 88	ETS 88				
								SNL 3088 TURT	–	TSD 3088 U	ETS 88 R				
								SNL 3088 TURA	–	TSD 3088 U	ETS 88 R				
410			420		1 030	260		SNL 3188 TS	SNL 3188	TS 88	ETS 88				
								SNL 3188 TNF	SNL 3188	TNF 88	ETS 88				
								SNL 3188 TURT	–	TSD 3188 U	ETS 88 R				
								SNL 3188 TURA	–	TSD 3188 U	ETS 88 R				
430			420		1 030	260		SNL 3092 TS	SNL 3092	TS 92	ETS 92				
								SNL 3092 TNF	SNL 3092	TNF 92	ETS 92				
								SNL 3092 TURT	–	TSD 3092 U	ETS 92 R				
								SNL 3092 TURA	–	TSD 3092 U	ETS 92 R				
430			440		1 070	260		SNL 3192 TS	SNL 3192	TS 92	ETS 92				
								SNL 3192 TNF	SNL 3192	TNF 92	ETS 92				
								SNL 3192 TURT	–	TSD 3192 U	ETS 92 R				
								SNL 3192 TURA	–	TSD 3192 U	ETS 92 R				
450			410		1 000	260		SNL 3096 TS	SNL 3096	TS 96	ETS 96				
								SNL 3096 TNF	SNL 3096	TNF 96	ETS 96				
								SNL 3096 TURT	–	TSD 3096 U	ETS 96 R				
								SNL 3096 TURA	–	TSD 3096 U	ETS 96 R				
450			460		1 110	260		SNL 3196 TS	SNL 3196	TS 96	ETS 96				
								SNL 3196 TNF	SNL 3196	TNF 96	ETS 96				
								SNL 3196 TURT	–	TSD 3196 U	ETS 96 R				
								SNL 3196 TURA	–	TSD 3196 U	ETS 96 R				
470			420		1 030	260		SNL 30/500 TS	SNL 30/500	TS 500	ETS 500				
								SNL 30/500 TNF	SNL 30/500	TNF 500	ETS 500				
								SNL 30/500 TURT	–	TSD 30/500 U	ETS 500 R				
								SNL 30/500 TURA	–	TSD 30/500 U	ETS 500 R				

For missing dimensions and availability please consult SKF

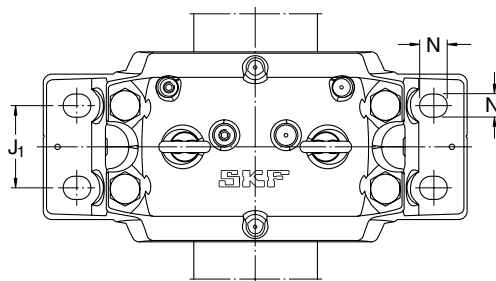
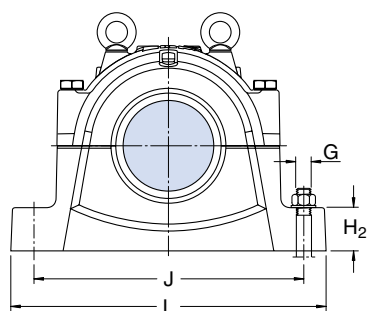

Shaft d_a	Bearing seating		Width across seals			Eye bolts according to DIN 580	Appropriate bearings and associated components		
	C_a	D_a	A_2	A_3	A_4		Spherical roller bearing	Adapter sleeve	Locating rings
mm	mm	mm	mm			—	—		
410		650					23088 CAK/W33		OH 3088 H
		720					23188 CAK/W33		OH 3188 H
430		680					23092 CAK/W33		OH 3092 H
		760					23192 CAK/W33		OH 3192 H
450		700					23096 CAK/W33		OH 3096 H
		790					23196 CAK/W33		OH 3196 H
470		720					230/500 CAK/W33		OH 30/500 H

For missing dimensions and availability please consult SKF

Large SNL plummer block housings for bearings with cylindrical bore
 d_a 170–300 mm

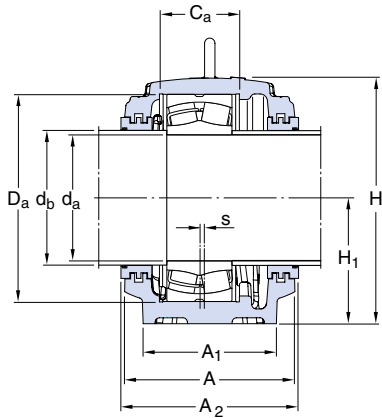

Labyrinth seals
TS design

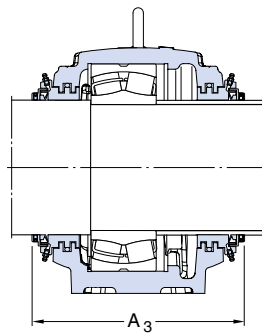

Taconite seals
TNF design

Shaft d_a	Housing Dimensions													Mass kg	Designations Housing complete with two seals	Components Housing only	Seal	End cover
	A	A ₁	H	H ₁	H ₂	J	J ₁	L	N	N ₁	s	G						
mm	mm													kg	–			
170	230	180	333	170	70	430	100	510	34	28	14	24	69,5	SNL 3134 GTS SNL 3134 GTNF	SNL 3134 G SNL 3134 G	TS 40 TNF 40	ETS 40 ETS 40	
180	230	180	333	170	70	430	100	510	34	28	14	24	69,5	SNL 3036 GTS SNL 3036 GTNF	SNL 3036 G SNL 3036 G	TS 44 TNF 44	ETS 44 ETS 44	
	240	190	353	180	75	450	110	530	34	28	15	24	77,5	SNL 3136 GTS SNL 3136 GTNF	SNL 3136 G SNL 3136 G	TS 44 TNF 44	ETS 44 ETS 44	
190	240	190	353	180	75	450	110	530	34	28	15	24	77,5	SNL 3038 GTS SNL 3038 GTNF	SNL 3038 G SNL 3038 G	TS 44 TNF 44	ETS 44 ETS 44	
	260	210	375	190	80	480	120	560	34	28	10	24	97,5	SNL 3138 GTS SNL 3138 GTNF	SNL 3138 G SNL 3138 G	TS 44 TNF 44	ETS 44 ETS 44	
200	260	210	375	190	80	480	120	560	34	28	10	24	97,5	SNL 3040 GTS SNL 3040 GTNF	SNL 3040 G SNL 3040 G	TS 48 TNF 48	ETS 48 ETS 48	
	280	230	411	210	85	510	130	610	42	35	10	30	123	SNL 3140 GTS SNL 3140 GTNF	SNL 3140 G SNL 3140 G	TS 48 TNF 48	ETS 48 ETS 48	
220	280	230	411	210	85	510	130	610	42	35	10	30	123	SNL 3044 GTS SNL 3044 GTNF	SNL 3044 G SNL 3044 G	TS 52 TNF 52	ETS 52 ETS 52	
	290	240	434	220	90	540	140	640	42	35	12	30	138	SNL 3144 GTS SNL 3144 GTNF	SNL 3144 G SNL 3144 G	TS 52 TNF 52	ETS 52 ETS 52	
240	290	240	434	220	90	540	140	640	42	35	12	30	139	SNL 3048 GTS SNL 3048 GTNF	SNL 3048 G SNL 3048 G	TS 56 TNF 56	ETS 56 ETS 56	
	310	260	474	240	95	600	150	700	42	35	12	30	187	SNL 3148 GTS SNL 3148 GTNF	SNL 3148 G SNL 3148 G	TS 56 TNF 56	ETS 56 ETS 56	
260	310	260	474	240	95	600	150	700	42	35	12	30	187	SNL 3052 GTS SNL 3052 GTNF	SNL 3052 G SNL 3052 G	TS 60 TNF 60	ETS 60 ETS 60	
	320	280	516	260	100	650	160	770	50	42	13	36	221	SNL 3152 GTS SNL 3152 GTNF	SNL 3152 G SNL 3152 G	TS 60 TNF 60	ETS 60 ETS 60	
280	320	280	516	260	100	650	160	770	50	42	13	36	221	SNL 3056 GTS SNL 3056 GTNF	SNL 3056 G SNL 3056 G	TS 64 TNF 64	ETS 64 ETS 64	
	320	280	551	280	105	670	160	790	50	42	16	36	252	SNL 3156 GTS SNL 3156 GTNF	SNL 3156 G SNL 3156 G	TS 64 TNF 64	ETS 64 ETS 64	
300	320	280	551	280	105	670	160	790	50	42	16	36	252	SNL 3060 GTS SNL 3060 GTNF	SNL 3060 G SNL 3060 G	TS 68 TNF 68	ETS 68 ETS 68	
	350	310	591	300	110	710	190	830	50	42	22	36	301	SNL 3160 GTS SNL 3160 GTNF	SNL 3160 G SNL 3160 G	TS 68 TNF 68	ETS 68 ETS 68	

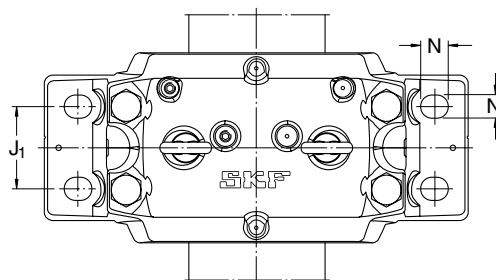
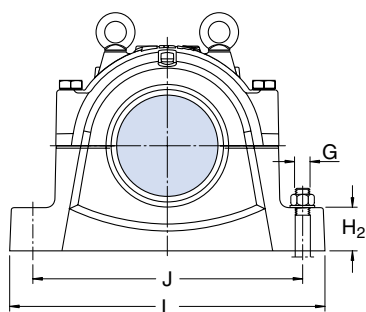

Shaft		Bearing seating		Width across seals		Eye bolts according to DIN 580	Appropriate bearings and associated components	
d _a	d _b	C _a	D _a	A ₂	A ₃		Spherical roller bearing	Locating rings
mm	mm	mm	mm	mm	mm	–	–	–
170	180	108	280	240	300	M 16	23134 CC/W33	2 FRB 10/280
180	200	108	280	240	310	M 16	23036 CC/W33 24036 CC/W33 C 3036	2 FRB 17/280 2 FRB 4/280 2 FRB 17/280
		116	300	250	315	M 16	23136 CC/W33 C 3136	2 FRB 10/300 2 FRB 10/300
190	200	115	290	250	315	M 16	23038 CC/W33 24038 CC/W33 C 3038	4 FRB 10/290 2 FRB 7,5/290 4 FRB 10/290
		124	320	270	335	M 20	23138 CC/W33	2 FRB 10/320
200	220	122	310	270	335	M20	23040 CC/W33 24040 CC/W33 C 3040	4 FRB 10/310 2 FRB 6,5/310 4 FRB 10/310
		132	340	290	355	M 20	23140 CC/W33 C 3140	2 FRB 10/340 2 FRB 10/340
220	240	130	340	290	360	M 20	23044 CC/W33 24044 CC/W33 C 3044	4 FRB 10/340 2 FRB 6/340 4 FRB 10/340
		140	370	300	365	M 20	23144 CC/W33 C 3144	2 FRB 10/370 2 FRB 10/370
240	260	140	360	300	380	M 20	23048 CC/W33 24048 CC/W33 C 3048	4 FRB 12/360 2 FRB 11/360 4 FRB 12/360
		148	400	315	400	M 24	23148 CC/W33 C 3148	2 FRB 10/400 2 FRB 10/400
260	280	148	400	315	400	M 24	23052 CC/W33 24052 CC/W33 C 3052	2 FRB 22/400 2 FRB 4/400 2 FRB 22/400
		164	440	330	415	M 24	23152 CC/W33 C 3152	2 FRB 10/440 2 FRB 10/440
280	300	166	420	330	415	M 24	23056 CC/W33 24056 CC/W33 C 3056	6 FRB 10/420 2 FRB 13/420 6 FRB 10/420
		166	460	330	415	M 24	23156 CC/W33 C 3156	2 FRB 10/460 2 FRB 10/460
300	320	168	460	330	415	M 24	23060 CC/W33 24060 CC/W33 C 3060	2 FRB 25/460 2 FRB 4/460 2 FRB 25/460
		180	500	360	445	M 30	23160 CC/W33 C 3160	2 FRB 10/500 2 FRB 10/500

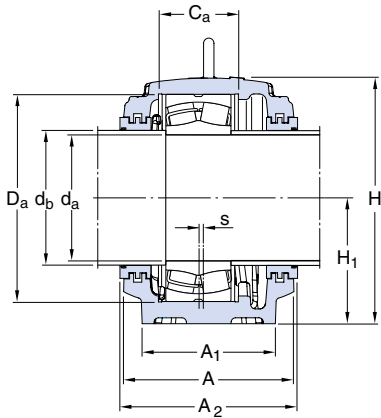

Labyrinth seals
TS design

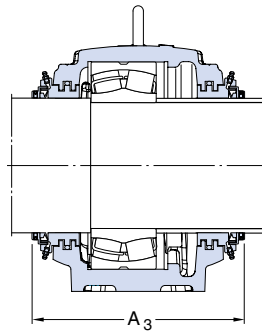

Taconite seals
TNF design

Shaft d _a	Housing Dimensions													Mass kg	Designations Housing complete with two seals	Components Housing only	Seal	End cover
	A	A ₁	H	H ₁	H ₂	J	J ₁	L	N	N ₁	s	G						
mm	mm													kg	–			
320	350	310	591	300	110	710	190	830	50	42	22	36	301	SNL 3064 GTS SNL 3064 GTNF	SNL 3064 G SNL 3064 G	TS 72 TNF 72	ETS 72 ETS 72	
	370	330	631	320	115	750	200	880	50	42	23	36	339	SNL 3164 GTS SNL 3164 GTNF	SNL 3164 G SNL 3164 G	TS 72 TNF 72	ETS 72 ETS 72	
340	370	330	631	320	115	750	200	880	50	42	23	36	339	SNL 3068 GTS SNL 3068 GTNF	SNL 3068 G SNL 3068 G	TS 76 TNF 76	ETS 76 ETS 76	
					340		810	220						SNL 3168 GTS SNL 3168 GTNF	SNL 3168 G SNL 3168 G			
360	370	330	631	320	115	750	200	880	50	42	23	36	339	SNL 3072 GTS SNL 3072 GTNF	SNL 3072 G SNL 3072 G	TS 80 TNF 80	ETS 80 ETS 80	
					350		840	220						SNL 3172 GTS SNL 3172 GTNF	SNL 3172 G SNL 3172 G			
380					340		810	220						SNL 3076 GTS SNL 3076 GTNF	SNL 3076 G SNL 3076 G			
					360		870	220						SNL 3176 GTS SNL 3176 GTNF	SNL 3176 G SNL 3176 G			
400					350		840	220						SNL 3080 GTS SNL 3080 GTNF	SNL 3080 G SNL 3080 G			
					380		950	240						SNL 3180 GTS SNL 3180 GTNF	SNL 3180 G SNL 3180 G			
420					360		870	220						SNL 3084 GTS SNL 3084 GTNF	SNL 3084 G SNL 3084 G			
					410	1 000	260							SNL 3184 GTS SNL 3184 GTNF	SNL 3184 G SNL 3184 G			
440					380		950	240						SNL 3088 GTS SNL 3088 GTNF	SNL 3088 G SNL 3088 G			
					420	1 030	260							SNL 3188 GTS SNL 3188 GTNF	SNL 3188 G SNL 3188 G			
460					420	1 030	260							SNL 3092 GTS SNL 3092 GTNF	SNL 3092 G SNL 3092 G			
					440	1 070	260							SNL 3192 GTS SNL 3192 GTNF	SNL 3192 G SNL 3192 G			

For missing dimensions and availability please consult SKF

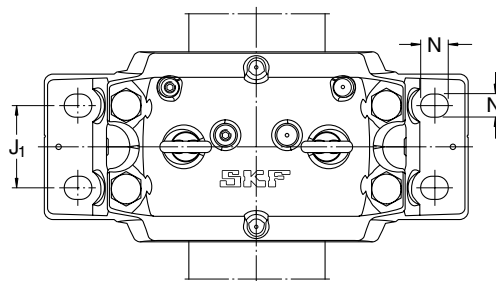
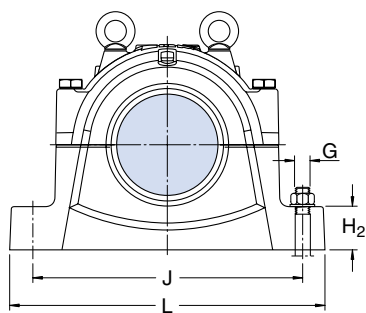

Shaft		Bearing seating		Width across seals		Eye bolts according to DIN 580	Appropriate bearings and associated components	
d _a	d _b	C _a	D _a	A ₂	A ₃		Spherical roller bearing	Locating rings
mm		mm		mm		—	—	
320	340	181	480	360	445	M 30	23064 CC/W33 24064 CC/W33	6 FRB 10/480 2 FRB 10,5/480
		C 3064 M						6 FRB 10/480
		196	540	380	465	M 30	23164 CC/W33 C 3164 M	2 FRB 10/540 2 FRB 10/540
340	360	197	520	380	465	M 30	23068 CC/W33 24068 CC/W33 C 3068 M	4 FRB 16/520 2 FRB 8,5/520 4 FRB 16/520
			580					
360	380	198	540	380	465	M 30	23072 CC/W33 24072 CC/W33	4 FRB 16/540 2 FRB 9/540
			600					
380			560				23076 CC/W33 24076 CC/W33	
			620				23176 CA/W33	
400			600				23080 CC/W33 24080 ECCJ/W33 C 3080 M	
			650				23180 CA/W33 C 3180 M	
420			620				23084 CA/W33 24084 ECA/W33	
			700				23184 C/W33	
440			650				23088 CA/W33 24088 ECA/W33	
			720				23188 CA/W33	
460			680				23092 CA/W33 24092 ECA/W33	
			760				23192 CA/W33	

For missing dimensions and availability please consult SKF

Large SNL plummer block housings
for bearings with cylindrical bore
d_a 480–500 mm

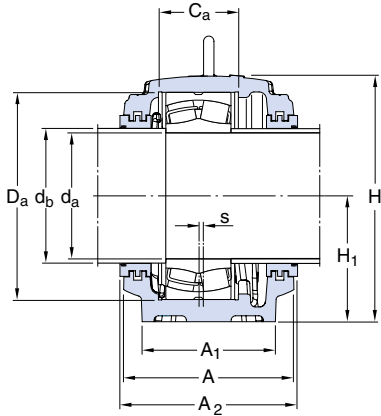

Labyrinth seals
TS design

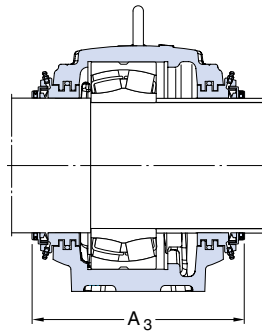

Taconite seals
TNF design

Shaft d _a	Housing Dimensions							J ₁	L	N	N ₁	s	G	Mass kg	Designations Housing complete with two seals	Components Housing only	Seal	End cover
	A	A ₁	H	H ₁	H ₂	J												
480			410		1 000	260									SNL 3096 GTS SNL 3096 GTNF	SNL 3096 G SNL 3096 G		
			460		1 110	260									SNL 3196 GTS SNL 3196 GTNF	SNL 3196 G SNL 3196 G		
500			420		1 030	260									SNL 30/500 GTS SNL 30/500 GTNF	SNL 30/500 G SNL 30/500 G		

For missing dimensions and availability please consult SKF

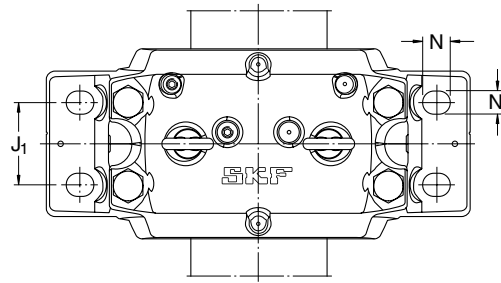
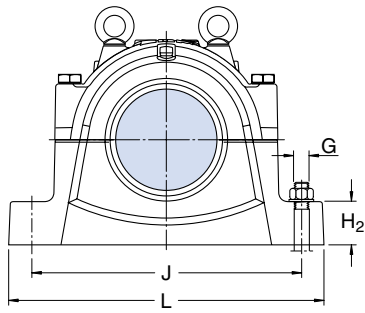

Shaft		Bearing seating		Width across seals		Eye bolts according to DIN 580	Appropriate bearings and associated components	
d _a	d _b	C _a	D _a	A ₂	A ₃		Spherical roller bearing	Locating rings
mm		mm		mm		—	—	
480			700				23096 CA/W33 24096 ECA/W33	
			790				23196 CA/W33	
500			720				230/500 CA/W33 240/500 ECA/W33	

For missing dimensions and availability please consult SKF

Other products for trouble-free operation

Robust, high-performance standard bearings

SKF produces the spherical roller bearings and CARB bearings normally incorporated in large SNL plummer block housings in many sizes and several designs. Both bearing types are self-aligning. The degree of misalignment which can be accommodated depends on the bearing series and also on the seals used in the SNL housings.

The spherical roller bearings can be used for both locating and non-locating bearing arrangements. At non-locating positions, the bearing outer ring is free to move axially in its seating in the housing bore. CARB bearings, on the other hand, accommodate axial displacements within the bearing and are always non-locating. It is usual to combine a CARB bearing at the non-locating side with a spherical roller bearing arranged as a locating bearing at the other side.

Spherical roller bearings

The spherical roller bearings which can be used in large SNL plummer block housings are those of series 230, 231 and 240. The bearings are available with tapered bore for mounting on adapter or withdrawal sleeves, or with cylindrical bore.

CARB bearings

These bearings are a recent addition to the range of ball and roller bearings offered by SKF and are an SKF invention. CARB bearings of series C 30 and C 31 can be incorporated in large SNL plummer block housings.

Although available in a caged as well as a full complement version, it is normally recommended that caged bearings are used in SNL housings. CARB bearings are available with a tapered bore for mounting on an adapter sleeve or a withdrawal sleeve, as well as with a cylindrical bore.



For easy mounting – adapter and withdrawal sleeves

Generally the bearings with a tapered bore incorporated in SNL plummer block housings are mounted on smooth or stepped shafts with the aid of an adapter sleeve or, on stepped shafts only, a withdrawal sleeve. These sleeves are produced by SKF in appropriate sizes for the range of bearings which can be used in SNL housings. The adapter sleeves are the more popular as they are more versatile and are easier to mount.

Adapter sleeves

These are slotted sleeves with a tapered outside diameter. The sizes used with bearings for SNL housings have an external taper of 1:12 and are supplied complete with lock nut and locking washer. Their dimensions are in accordance with ISO 2982-1:1995.

When using adapter sleeves on smooth shafts it is possible to locate the bearing at any position on the shaft and no additional axial location is required.

Withdrawal sleeves

These are also slotted sleeves with a tapered outside diameter. The sizes used with bearings for SNL housings have an external taper of 1:12. Their dimensions are in accordance with ISO 2982-1:1995.

Bearings on withdrawal sleeves must be mounted against a fixed abutment, e.g. a shaft shoulder. The withdrawal sleeve must be secured in position after it has been pressed into the bearing bore by a lock nut or end plate on the shaft. The nuts are not supplied with the sleeves.

More information about

- *spherical roller bearings* (→ brochure 5100)
- *CARB bearings* (→ brochure 5102)
- *adapter and withdrawal sleeves* (→ catalogue 3766)



Other products

Lock nuts

SKF lock nuts, also referred to as shaft nuts, are available in several designs to axially locate bearings on shaft ends. The most popular are those of series KM, KML and HM. These nuts have four or eight equally spaced slots in the outside diameter and are locked in position with locking washers or locking clips engaging a groove in the shaft. The nut dimensions are in accordance with ISO 2982-2:1995 as are the dimensions of the series MB and MBL locking washers.

Other lock nuts produced by SKF include those of series KMT, KMTA, KMK and KMFE, that do not require a groove in the shaft.



Lubricating greases for bearings

Lubrication is a necessity for proper bearing performance. Grease is normally used for applications involving SNL plummer blocks. SKF has put considerable effort into establishing a range of high-quality greases for ball and roller bearing lubrication.

The SKF SYSTEM 24 automatic lubricator can also be used with SNL plummer block housings. An adapter can be fitted to the standard drilled and tapped hole in the housing cap. It should be remembered that surplus grease should be able to leave the housing.



Pop Release units

These units are plummer blocks with ready-lubricated bearings for easy installation. They comprise

- a one-piece plummer block housing of grey cast iron,
- a spherical roller bearing of series 222 with special inner ring,
- a special adapter sleeve, and
- two seals of the "TriGard" type or two labyrinth seals.

The units are available in a locating and a non-locating version.



Other bearing housings

To meet a wide variety of application demands, SKF produces a comprehensive range of bearing housings. The majority of these are of the split plummer block type but the SKF range also includes

- one-piece plummer block housings,
- flanged housings,
- take-up housings, and
- two-bearing housings.

Most of these housings are designed to take self-aligning bearings, and the range extends to shaft diameters up to and including 1 800 mm. Housings are available for oil lubrication as well as

grease lubrication and also for bearings with cylindrical bore or for tapered bore, mounted on adapter or withdrawal sleeves. Smooth or stepped shafts can be used.

Various different types of seal are used. Most housings are made of grey cast iron but spheroidal graphite cast iron or cast steel housings are included in the range.

For further information, please contact SKF.

More information about

- *lock nuts* (→ *brochure 4412 and catalogue 3766*)
- *greases* (→ *catalogue MP3000*)
- *Pop Release units* (→ *brochure 5103*)
- *housings* (→ *catalogue 4005*)



Condition monitoring equipment

The goals of condition monitoring are to maximise the time that the machine is functioning well and to minimise the number of breakdowns, thereby significantly reducing operating downtime and maintenance cost.

To achieve this, it is recommended that the bearing and machine condition be monitored either periodically or continuously. Condition monitoring enables incipient bearing damage to be detected and evaluated, so that bearing replacement can be scheduled for a time when the machine is not in operation, to avoid unplanned stoppages. Applied to all machinery (not just sensitive or problematic machines), condition monitoring improves machinery operation to an optimum level, often exceeding the original equipment specifications.

SKF provides a comprehensive range of condition monitoring equipment to measure all important parameters. These include

- temperature,
- speed,
- noise,
- oil condition,
- shaft alignment,
- vibration and
- bearing condition.

The range includes lightweight, hand-held devices for manual use as well as complex continuous monitoring systems for fixed installations in connection with preventive maintenance.

One example is the Machine Reliability Inspection System MARLIN™ which is at the leading edge of technology and allows storage of up to 2 000 measuring points. It can be used to diagnose machines and individual bearings and is backed by tailored software for the evaluation of the readings including enveloping vibration acceleration curves.



Recording vibration values using an SKF Microlog data collection unit

Taking the temperature



Noise testing



The MARLIN™ machine reliability inspection system



The SKF Group - a worldwide corporation

SKF is an international industrial Group operating in some 130 countries and is world leader in bearings.

The company was founded in 1907 following the invention of the self-aligning ball bearing by Sven Wingquist and, after only a few years, SKF began to expand all over the world.

Today, SKF has some 40 000 employees and around 80 manufacturing facilities spread throughout the world. An international sales network includes a large number of sales companies and some 7 000 distributors and retailers. Worldwide availability of SKF products is supported by a comprehensive technical advisory service.

The key to success has been a consistent emphasis on maintaining the highest quality of its products and services. Continuous investment in research and

development has also played a vital role, resulting in many examples of epoch-making innovations.

The business of the Group consists of bearings, seals, special steel and a comprehensive range of other high-tech industrial components. The experience gained in these various fields provides SKF with the essential knowledge and expertise required in order to provide the customers with the most advanced engineering products and efficient service.



SKF



The SKF Group is the first major bearing manufacturer to have been granted approval according to ISO 14001, the international standard for environmental management systems. The certificate is the most comprehensive of its kind and covers more than 60 SKF production units in 17 countries.



The SKF Engineering & Research Centre is situated just outside Utrecht in The Netherlands. In an area of 17 000 square metres (185 000 sq.ft) some 150 scientists, engineers and support staff are engaged in the further improvement of bearing performance. They are developing technologies aimed at achieving better materials, better designs, better lubricants and better seals – together leading to an even better understanding of the operation of a bearing in its application. This is also where the SKF Life Theory was evolved, enabling the design of bearings which are even more compact and offer even longer operational life.



SKF has developed the Channel concept in factories all over the world. This drastically reduces the lead time from raw material to end product as well as work in progress and finished goods in stock. The concept enables faster and smoother information flow, eliminates bottlenecks and bypasses unnecessary steps in production. The Channel team members have the knowledge and commitment needed to share the responsibility for fulfilling objectives in areas such as quality, delivery time, production flow etc.



SKF manufactures ball bearings, roller bearings and plain bearings. The smallest are just a few millimetres (a fraction of an inch) in diameter, the largest several metres. SKF also manufactures bearing and oil seals which prevent dirt from entering and lubricant from leaking out. SKF's subsidiaries CR and RFT S.p.A. are among the world's largest producers of seals.



® SKF and CARB are registered trademarks of SKF.

© Copyright SKF 2001

The contents of this publication are the copyright of the publisher and may not be reproduced (even extracts) unless permission is granted. Every care has been taken to ensure the accuracy of the information contained in this publication but no liability can be accepted for any loss or damage whether direct, indirect or consequential arising out of the use of the information contained herein.

Publication **5101 E** · June 2001

Printed in Sweden on environmentally friendly, chlorine-free paper (Multiart Silk) by Hyltebruks Tryckeri AB.

www.skf.com